



HEAVY DUTY
MILL TYPE
CYLINDERS(IMPERIAL)



Index

GENERAL INFORMATION

Anker-Holth Product Guide 2
 Materials Specifications 4
 Cylinders Selection Criteria 5
 Cylinder Bore Selection 6
 Rod Selection 8

BASE MOUNT

200 PSI Air Mill Cylinder 10
 2000 PSI Hydraulic Mill Cylinder 11
 3000 PSI Hydraulic Mill Cylinder 11

TRUNNION MOUNT

200 PSI Air Mill Cylinder 12
 2000 PSI Hydraulic Mill Cylinder 13
 3000 PSI Hydraulic Mill Cylinder 13

FRONT FLANGE MOUNT

200 PSI Air Mill Cylinder 14
 2000 PSI Hydraulic Mill Cylinder 15
 3000 PSI Hydraulic Mill Cylinder 15

REAR FLANGE MOUNT

200 PSI Air Mill Cylinder 16
 2000 PSI Hydraulic Mill Cylinder 17
 3000 PSI Hydraulic Mill Cylinder 17

MALE CLEVIS MOUNT

200 PSI Air Mill Cylinder 18
 2000 PSI Hydraulic Mill Cylinder 19
 3000 PSI Hydraulic Mill Cylinder 19

FEMALE CLEVIS MOUNT

200 PSI Air Mill Cylinder 20
 2000 PSI Hydraulic Mill Cylinder 21
 3000 PSI Hydraulic Mill Cylinder 21

CYLINDER DISPLACEMENT & FLOW

..... 22

CYLINDER FORCE & SPEED

..... 23

ACCESSORIES

Female Rod Eye 24
 Female Rod Clevis 24
 Female Rod Eye / Spherical Bearing 25
 Rod End Jam Nut 25
 Clevis Bracket 26
 Eye Bracket 26
 Cotter / Pivot Pin 27
 Snap Ring / Pivot Pin 27
 Greased Snap Ring / Pivot Pin 27

PORT OPTIONS

..... 28

Order Code System

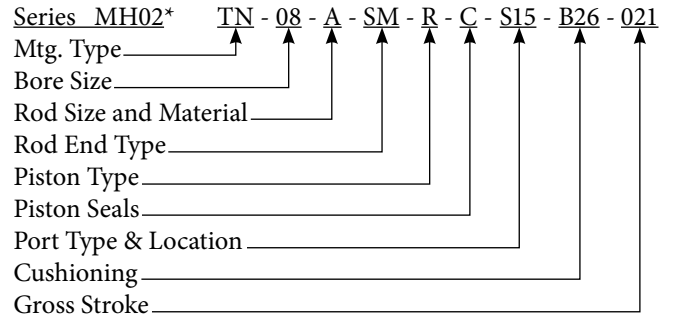

Series

- MA02= Mill Style; Pneumatic; 200 PSI nominal
- MH01= Mill Style; Hydraulic; 2000 PSI nominal
- MH31= Mill Style; Hydraulic; 3000 PSI nominal

Mounting Type

- TN = Trunnion FC = Female Clevis
- MC = Male Clevis BM = Base Mount
- RF = Rear Flange FF = Front Flange

Rod Size and Material

- A = Standard Diameter; Steel Hard Chrome Plated
- B = First Option Diameter; Steel Hard Chrome Plated
- S = Special Diameter, Material and/or Finish

Rod End Type

- SM = Standard Male
- SF = Standard Female
- SS = Special

Piston Type

- W = Ductile Iron or Steel with High Load Wear Ring
- R = 2 piece Steel with High Load Wear Ring
- C = Ductile Cast Iron; High Graphite Content
- S = Bronze Clad Steel
- X = Other

Piston Seals

- C = Chevron U = U-cup
- P = Polypack style E = Bi-directional with energizer
- T = PTFE (Teflon) X = Other

Port Type and Location*

- J = SAE "0" Ring Boss
- F = SAE 4-Bolt Flange
- P = NPT pipe thread

Cushioning*

- N = None
- F = Front End
- R = Rear End
- B = Both Ends

* Locations are 1-4 for front heads and 5-8 for rear heads as illustrated in cylinder drawings.

Note: Non-standard dimensions, special materials, stop tubes or additional features and all mounting accessories must be specified separately.

Anker-Holth Product Guide

Mill Duty Cylinders

APPLICATIONS Metals processing, power generation, petro-chemical, light and heavy manufacturing



FEATURES

Bore: Up to 40" (1000 mm)
Stroke: Up to 60' (18 m)
Sizes: Inch or metric
Pressure: Up to 3000 PSI (200 bar)
Temperature: -60° F to 600° F (-50° C to 300° C)
Material: Steel, stainless steel, special alloys

BENEFITS

- Adapted to fit all applications
- Designed for harsh environments such as steel mills and mining
- Mounting designed to suit customer needs
- Cylinders built to withstand buckling from compressive loads
- Used in corrosive or non-corrosive environments

High Pressure Mill Cylinders

APPLICATIONS Metals processing, mining, material handling, military, offshore exploration, R & D



FEATURES

Bore: Up to 40" (1000 mm)
Stroke: Up to 60' (18 m)
Sizes: Inch or metric
Pressure: Up to 5000 PSI (350 bar)
Temperature: -60° F to 600° F (-50° C to 300° C)
Material: Steel, stainless steel, special alloys

BENEFITS

- Long service life
- High pressure applications such as mining, bailers and presses
- Can be used in corrosive environments
- Built to withstand abusive applications
- Built to meet customer mounting specifications

Torpedo Cylinders

APPLICATIONS Metals processing, mining, limited space applications, military, R & D, steel mills, aluminum smelters



FEATURES

Bore: Up to 40" (1000 mm)
Stroke: Up to 60' (18 m)
Sizes: Inch or metric
Pressure: Up to 3000 PSI (200 bar)
Temperature: -60° F to 600° F (-50° C to 300° C)
Material: Steel, stainless steel, special alloys

BENEFITS

- Air and hydraulic applications
- Thin profile for tight space limitations
- Can withstand high heat environments
- Advantages of mill duty in compact design
- Piloted head ensures positive alignment
- Streamlined sturdy design

Rotating Cylinders

APPLICATIONS Metals processing, rolling mills, pulp and paper, lathes, winders, coilers, mandrels

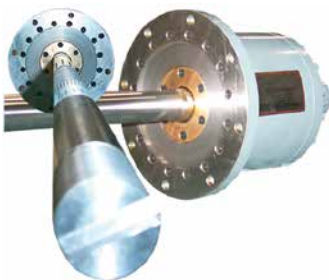

FEATURES

Bore: Up to 40" (1000 mm)
Pressure: Up to 3000 PSI (200 bar)

- One-piece piston
- Double ball bearings
- Self-adjusting packings
- Streamlined, sturdy, dependable

BENEFITS

- Long service life and low maintenance
- No end thrust; minimum friction
- Rugged design for air and hydraulic winders, lathes and mandrels
- Bolt-on hydraulic or air inlet assemblies for easy maintenance
- Simple design for easy packing replacement
- Safely reaches high speeds

DC Casting Cylinders

APPLICATIONS Direct chill casting machines for aluminum, copper, magnesium, and all non-ferrous alloys



FEATURES

Stroke: Up to 40' (12 m)
Sizes: Inch or metric
Ram diameter: Up to 30" (760 mm)
Pressure: Up to 3000 PSI (200 bar)
Material: Steel, stainless steel, special alloys

BENEFITS

- Single or double acting
- Rotation limited to four minutes
- Internally or externally guided
- Cushioned or non-cushioned
- Will withstand buckling from excessive compressive and eccentric loads
- Mounting designed to suit customer needs

Automatic Gauge Control (AGC) Cylinders

APPLICATIONS Ferrous and non-ferrous single stand or tandem rolling mills



FEATURES

Bore: Up to 50" (1270 mm)
Sizes: Inch or metric
Pressure: Up to 10,000 PSI (690 bar)
Includes: Magnetic transducers

BENEFITS

- Long service life
- Designed for corrosive environments
- Can be supplied with AGC electronics hardware and software for a completely automated project

Tie Rod Cylinders

APPLICATIONS Automotive, off-road equipment, steel and aluminum mills, hydraulic platforms, etc.



FEATURES

Bore: Up to 20" (500 mm)
Pressure: Up to 3000 PSI (200 bar)
Temperature: -60° F to 600° F (-50° C to 300° C)

- One-piece piston
- Self-adjusting packing
- Polyurethane rod wipers
- Streamlined, sturdy, dependable

BENEFITS

- Long service life
- No end thrust
- Minimum friction
- Low maintenance
- Rugged, air or hydraulic design
- Designed for easy packing replacement

Special Application Cylinders



Custom design



Rams



One-piece stainless steel

Quality Products

Materials Specifications

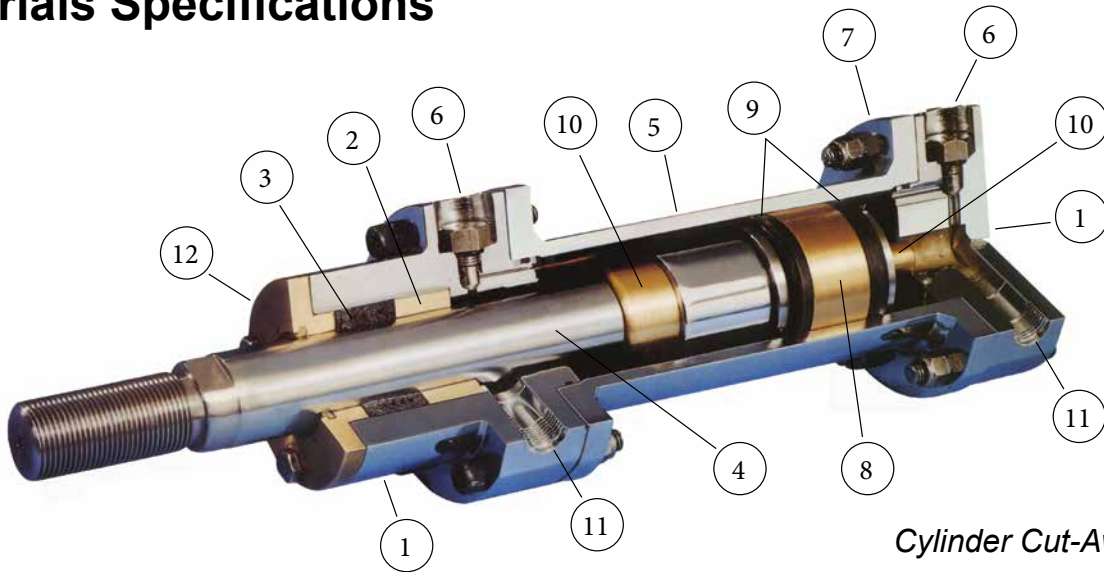

Cylinder Cut-Away

Cylinder Parts

- | | |
|--|-------------------|
| 1. Head & Cap | 7. Body Flange |
| 2. Wear Bands or bushings | 8. Piston |
| 3. Seals | 9. Piston Seals |
| 4. Piston Rod | 10. Cushion |
| 5. Steel tube, Cylinder body or Barrel | 11. Pressure Port |
| 6. Adjustable cushioning | 12. Gland |

Cylinder Body Materials

- Sizes up to 10 inch, cold drawn or mechanical seamless heavy wall tubing grades SAE 1018-1026 or better.
- Sizes over 10 inches are ASTM-A-53 or A-106 grades A through C seamless carbon steel tubing or centrifugal cast A-27 as required by application.
- Inside finishes, honed to a 16 micro-inch finish or better with finer finishes upon request.
- Cylinder heads are piloted into the barrel to ensure proper alignment.

Heads

- Machined from high quality steel plate to withstand higher stress and fatigue.
- Heads and caps, assembled to the flanged tube using high strength socket head cap screws and nuts.

Ports

- Available in SAE straight thread, 4-Bolt flange, NPT thread or metric sized ports.

Pistons

- High graphite content, cast-iron pistons provide excellent self-lubrication for long service life. Wear rings and bronze cladding are also available as options.

Piston Seals

- U-cup seals are standard for air cylinders. Hydraulic cylinders with medium duty push/pull applications use bi-directional seals. Chevron seals are used for heavy-duty application & for ease of maintenance. PTFE is Ideal for low-friction applications.

Piston Rods

- Manufactured from high tensile steel for strength and hard chrome plated for long wear.

Cushion Assembly

- Unique stainless steel check valve facilitates trouble-free system start up.
- Single point access uses standard tools for cushion adjustment.
- Proven design ensures proper seating between poppet and seat.

Rod Gland Assembly

- Machined from SAE 660 bronze for superior bearing properties and extended service.
- Bolted flange facilitates shimming, does not loosen, and uses standard tools to ease maintenance.

Optional Features

- All standard features listed above may be substituted to better suit system requirements.

Cylinders Selection Criteria

Mill-Type Cylinders

The following steps specify the information required to provide the correct cylinder for your application:

1. **Bore Size:** Dependent on the amount of force required and available system pressure. Charts on pages 4 and 5 determine the required size.
2. **Rod Size:** The standard and optional rod diameters for a given bore cylinder within a series are identified in dimensional charts for each mounting type. See pages 6 and 7 for piston rod selection instructions.
3. **Rod End Type:** Both male and female rod ends are available as standard. Other styles, lengths and threads are available as options. If non-standard rod ends are required, be sure to clearly specify all details.
4. **Stop Tubes:** Indicated in the instructions for piston rod selection, specify actual working stroke, Stop tube length & Gross cylinder stroke.
5. **Trunnion Locations:** Specify the X dimension.

Cylinder Cushioning

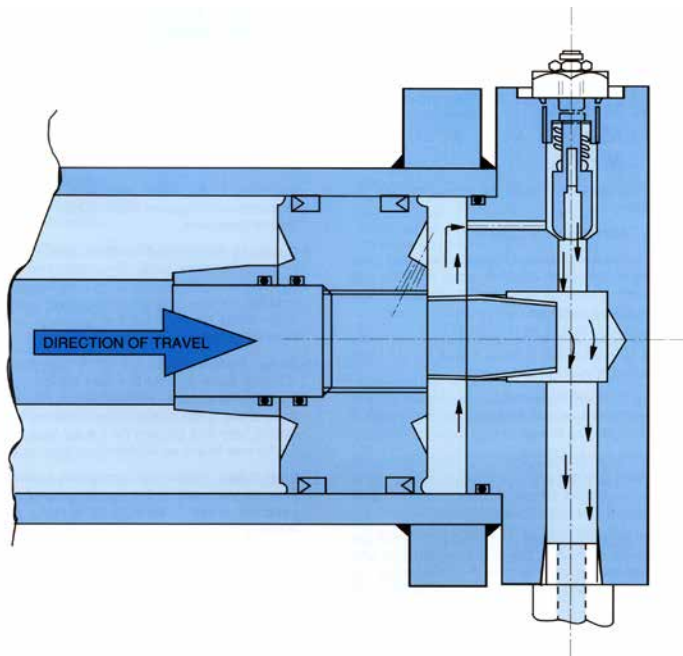

Rear Head Cylinder Cushioning

Cylinder cushions are designed to decelerate the speed of piston and rod assemblies as they approach the end of their stroke. This is accomplished by reducing the flow of exhausting fluid from within the cylinder. As the cushion plunger enters the cushion chamber, fluid flow through the primary outlet is gradually closed off, forcing the remaining fluid to exhaust through a patented by-pass throttling check valve assembly. In order to regulate the speed of closure, loosen the jam nut and adjust the valve stem tension set screw using a standard Allen wrench. After adjustment, be sure to tighten the jam nut to ensure a constant cushion action.

For fast, smooth starts during return strokes, the poppet portion of the valve assembly rises from its seat under pressure allowing full flow through the otherwise restricted passageway.

For added safety during adjustment, the valve stem has been isolated from the stem set screw and encapsulated in the cushion assembly cavity.

In hydraulic applications, moving parts for this assembly are manufactured entirely from stainless steel for long life and trouble-free service. Air cylinders use stainless steel and nylon components. Cushion plungers are tapered and precision machined for smooth entry into the cushion chamber, providing gradual, uniform deceleration.

Cylinder Bore Selection

Given Push Stroke Force and System Pressure

The following steps are used to calculate cylinder bore size based upon push force requirements.

1. At the top of the chart, locate your system pressure designated in PSI.
2. Moving down the system pressure column, locate the push (P/S) force value representing the thrust requirement for your cylinder's mechanical motion. If the exact thrust is not given, go to the next larger value.
3. On the same line as your force value, select the corresponding bore diameter in the far left-hand vertical column. Gallons displaced per inch of stroke are given at the far right.

Given Pull Stroke Force and System Pressure

To calculate available pull force, proceed with the following steps.

1. From the catalog, obtain the standard rod diameter for the appropriate series cylinder and bore diameter as determined in the push calculations.
2. From the table, find the rod diameter in the vertical rod diameter column adjacent to the appropriate cylinder bore.
3. Moving across the column to the right, find the available pull force value for your system's given pressure as indicated across the top of the table.

If the cylinder originally selected does not provide adequate pull forces, a larger bore cylinder must be selected.

Note: that available rod diameters for each bore size are listed in the chart below the push (P/S) designation. Later calculations will determine if standard rod diameters meet the column strength requirements for your application.

Other Considerations

All cylinder bore calculations listed here are theoretical. Power loss due to friction within the cylinder due to the weight of the piston and rod should be compensated for by reducing calculated figures depending on the bore and rod size.

- As bore and rod sizes increase so does power loss due to friction. Additionally, abnormal system pressure drop may affect calculations. To minimize pressure drop, be sure line sizes are within recommended velocity ranges for a given pump output. Actual system operating pressure may be determined by gauging the line pressure nearest the cylinder's intended installed location.
- For thrust requirements greater than those given in the table, calculate bore diameters by dividing the required force in pounds by the available system pressure stated in pounds per square inch. Your result will be the square inches of area required at a given pressure to generate the required force. This figure can then be matched to the effective working area column in the chart to determine cylinder bore requirements.
- For non-standard piston rod diameters larger than those given in the table, available pull force may be calculated by determining the piston rod's area in square inches, multiplying this figure by the available system pressure and deducting the resultant force figure from that available for the push stroke.
- Low temperatures, unusual fluids and long pipe runs may also cause pressure drop. Under these conditions, consult Anker-Holth for bore recommendations.

Push and Pull Stroke Forces in Lbs

Bore Diameter (inches)	Rod Diameter (inches)	Effective Working Area	80 PSI	100 PSI	200 PSI	250 PSI	500 PSI	750 PSI	1000 PSI	1500 PSI	2000 PSI	3000 PSI	Gallons Displaced per inch of Stroke
2	P/S	3.1416	251	314	628	785	1,571	2,356	3,142	4,712	6,283	9,425	0.0136
	1	2.3562	188	235	471	589	1,178	1,767	2,356	3,534	4,712	7,069	0.0102
	1.375	1.6567	133	166	331	414	828	1,243	1,657	2,485	3,313	4,970	0.0071
3	P/S	7.0686	565	707	1,414	1,767	3,534	5,301	7,069	10,603	14,137	21,206	0.0306
	1.375	5.5837	447	558	1,117	1,396	2,792	4,188	5,584	8,376	11,167	16,751	0.0241
	1.750	4.6633	373	466	933	1,166	2,332	3,497	4,663	6,995	9,327	13,990	0.0201
4	P/S	12.5664	1,005	1,257	2,513	3,142	6,283	9,425	12,566	18,850	25,133	37,699	0.0544
	1.750	10.1611	813	1,016	2,032	2,540	5,081	7,621	10,161	15,242	20,322	30,483	0.0440
	2	9.4248	754	942	1,885	2,356	4,712	7,069	9,425	14,137	18,850	28,274	0.0408
5	P/S	19.6350	1,571	1,963	3,927	4,909	9,817	14,726	19,635	29,452	39,270	58,905	0.0850
	2	16.4934	1,319	1,649	3,299	4,123	8,247	12,370	16,493	24,740	32,987	49,480	0.0714
	2.5	14.7263	1,178	1,473	2,945	3,682	7,363	11,045	14,726	22,089	29,453	44,179	0.0637
6	P/S	28.2743	2,262	2,827	5,655	7,069	14,137	21,206	28,274	42,411	56,549	84,823	0.1224
	2.5	23.3656	1,869	2,337	4,673	5,841	11,683	17,524	23,336	35,048	46,731	70,097	0.1011
	3	21.2057	1,696	2,121	4,241	5,301	10,603	15,904	21,206	31,809	42,411	63,617	0.0918
7	P/S	38.4845	3,079	3,848	7,697	9,621	19,242	28,863	38,484	57,727	76,969	115,453	0.1666
	2.5	33.5758	2,686	3,358	6,715	8,394	16,788	25,182	33,576	50,364	67,152	100,727	0.1453
	3.5	28.8634	2,309	2,886	5,773	7,216	14,432	21,648	28,863	43,295	57,727	86,590	0.1249
8	P/S	50.2655	4,021	5,027	10,053	12,566	25,133	37,699	50,265	75,398	100,531	150,796	0.2176
	2.5	45.3568	3,629	4,536	9,071	11,339	22,678	34,018	45,359	68,035	90,714	136,070	0.1963
	3	43.1969	3,456	4,320	8,639	10,799	21,598	32,398	43,197	64,795	86,394	129,591	0.1869
10	P/S	78.5398	6,283	7,854	15,708	19,635	39,270	58,905	78,540	117,810	157,080	235,619	0.3400
	3	71.4712	5,718	7,147	14,294	17,868	35,736	53,603	71,471	107,207	142,942	214,414	0.3094
	3.5	68.9187	5,513	6,892	13,784	17,230	34,459	51,689	68,919	103,378	137,837	206,756	0.2983
12	P/S	113.0973	9,048	11,310	22,619	28,274	56,549	84,823	113,097	169,646	226,195	339,292	0.4896
	3	106.0287	8,482	10,603	21,206	26,507	53,014	79,522	106,029	159,043	212,057	318,086	0.4589
	4.25	98.9113	7,913	9,891	19,782	24,728	49,456	74,183	98,911	148,367	197,823	296,734	0.4281
14	P/S	153.9380	12,315	15,394	30,788	38,484	76,969	115,453	153,938	230,907	307,876	461,814	0.6664
	3.5	144.3169	11,545	14,432	28,863	36,079	72,158	108,238	144,317	216,475	288,634	432,951	0.6247
	5.75	127.971	10,238	12,797	25,594	31,993	63,985	95,978	127,971	191,956	255,942	383,913	0.5539
16	P/S	201.0619	16,085	20,106	40,212	50,265	100,531	150,796	201,062	301,593	402,124	603,186	0.8704
	3.5	191.4408	15,315	19,144	38,288	47,860	95,720	143,581	191,441	287,161	382,882	574,322	0.8287
	5.75	175.0949	14,008	17,509	35,019	43,774	87,547	131,321	175,095	262,642	350,190	525,285	0.7579
	7	162.5769	13,006	16,258	32,515	40,644	81,288	121,933	162,577	243,865	325,154	487,731	0.7038
	8	150.7969	12,064	15,080	30,159	37,699	75,398	113,098	150,797	226,195	301,594	452,391	0.6528
	10	122.5219	9,802	12,252	24,504	30,630	61,261	91,891	122,522	183,783	245,044	367,566	0.5304

Rod Selection

Column Strength Considerations

When considering the use of long stroke cylinders, column strength must be carefully evaluated. Involved in these considerations are the total extended rod length, the support received at the rod end connection, piston and head end bearings and the style of mounting. A stop tube positioned on the rod between the piston and cylinder head is commonly used to act as a spacer increasing the distance between the piston and piston rod bearing when the cylinder is in its fully extended position. This increased spacing distributes bearing loads while increasing the structural rigidity of the rod to prevent jack-knifing or buckling.

Determining Need for Stop Tubes

The following steps are used to determine need for and length of stop tubes. Note that stop tubes are not normally required for cylinders operating primarily in the pull mode.

1. From the groups of cylinders exhibited on the next page, determine the configuration corresponding to your application.
2. A stop tube is recommended for cylinders mounted as shown in Cases I and III whenever the calculated “L” dimension exceeds 40 inches.
3. Use one inch of stop tube for every 10 inches of length over basic 40 inch “L” value.
4. Cylinders mounted as those shown in Cases II and IV do not normally require stop tubes. There may, however, be unusual circumstances where stop tubes may be required. These circumstances normally relate to cylinders in a horizontal plane where excessive combined cylinder and fluid weights are a factor.

When ordering cylinders with stop tubes, be sure to call out the net stroke of the rod and length of the stop tube. This combined length is commonly referred to as the “gross stroke”.

When in doubt, contact Anker-Holth for recommendations or visit our website at www.ankerholth.com.

Piston Rod Column Strength Factors

The cylinder’s piston rod acts as a column and, as such, is subject not only to compressive stresses, but also to buckling stresses which are a function of the moment of inertia for a constant modulus of elasticity. The “column strength” of a piston rod cannot be increased by using higher tensile strength or heat-treated materials. For this reason, it is sometimes necessary to use an oversized piston rod strictly for the purpose of achieving the necessary “column strength”.

Rod Diameter Considerations for Long Push Stroke Cylinders

The following steps are used to determine required rod diameters using the table on the next page.

1. From the groups of cylinders exhibited, determine the configuration corresponding to your application.
2. Calculate the “L” value for the cylinder corresponding to your application with the piston rod in its fully extended position.
3. Locate the maximum thrust required for your application from the vertical left hand column of the Piston Rod Selector Chart.
4. Moving across the column to the right, select the “L” value equal to your calculations in step 2. If the exact thrust is not given, go to the next larger value.
5. Moving up the “L” value column, note the appropriate piston rod diameter at the top of the chart.

In some cases the recommended piston rod diameter may exceed that of the largest standard piston rod available for the cylinder selected. In this case, it may be necessary to use a larger bore cylinder and operate at reduced system pressures in order to obtain the required column strength provided by the larger rod.

Rod diameters indicated in our chart represent the maximum thrust values for a given “L” dimension and may be considered safe for most normal cylinder applications. It should be noted, however, that for long stroke horizontally mounted cylinders subjected to severe shock loading, it may be desirable to increase the value of “L” by one-third prior to selecting the rod diameter.

Column Strength Factors

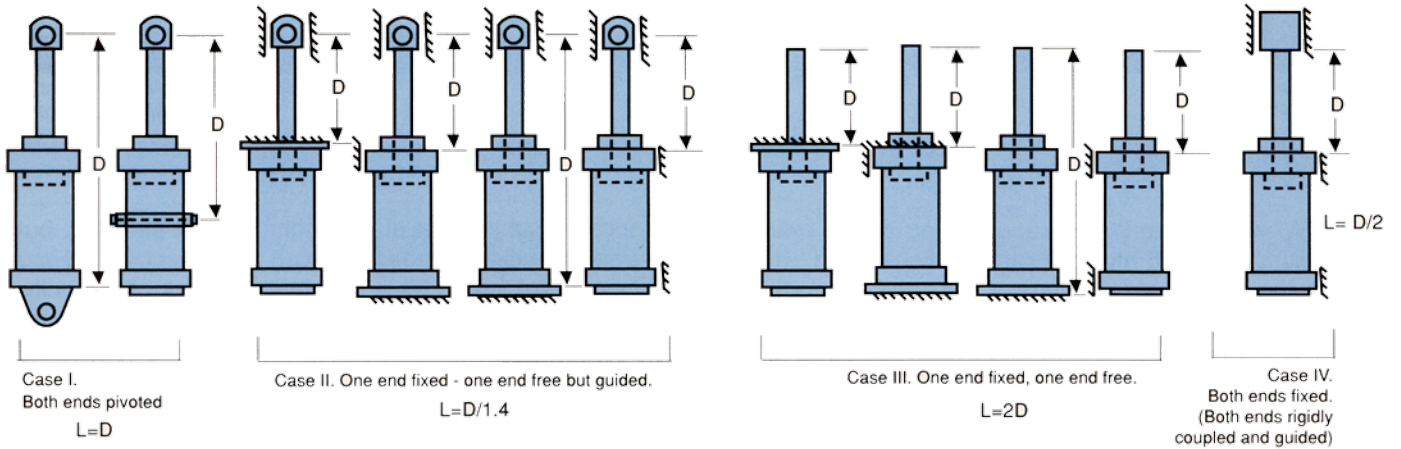

Piston Rod Diameter	1	1 3/8	1 3/4	2	2 1/2	3	3 1/2	4	4 1/2	5	5 1/2	7	8	10
Thrust (in Lbs)														
100	191	360												
200	135	255												
300	110	208	337											
400	95	180	292											
500	85	161	261	341										
750	70	132	213	278										
1,000	60	114	185	241	377									
1,250	54	102	165	216	337	485								
1,500	49	93	151	197	308	443								
1,750	46	86	140	182	285	410								
2,000	43	81	131	170	266	384								
2,500	38	72	117	152	238	343	467							
3,000	35	66	107	139	218	313	426							
4,000	30	57	92	121	188	271	369							
5,000	27	51	83	108	168	243	330	431						
6,000	25	47	75	98	154	221	301	394						
8,000	21	40	65	85	133	192	261	341	432					
10,000	19	36	58	76	119	172	234	305	386					
15,000	16	29	48	62	97	140	191	249	315	389				
20,000	13	25	41	54	84	121	165	216	273	337	408			
30,000	11	21	34	44	69	99	135	176	223	275	333			
40,000	10	18	29	38	60	86	117	152	193	238	288	467		
50,000		16	26	34	53	77	104	136	173	213	258	418		
60,000		15	24	31	49	70	95	125	158	195	235	381	498	
80,000		13	21	27	42	61	83	108	136	168	204	330	431	
100,000			18	24	38	54	74	96	122	151	182	295	386	
150,000			15	20	31	44	60	79	100	123	149	241	315	492
200,000			13	17	27	38	52	68	86	107	129	209	273	426
500,000				11	17	24	33	43	55	67	82	132	173	270
1,000,000					12	17	23	30	39	48	58	93	122	191
2,000,000						12	17	22	27	34	41	66	86	135
3,000,000							13	18	22	28	33	54	70	110
4,000,000								12	15	19	24	29	47	95
5,000,000									14	17	21	26	42	85
6,000,000										12	16	19	24	38

Base Mount

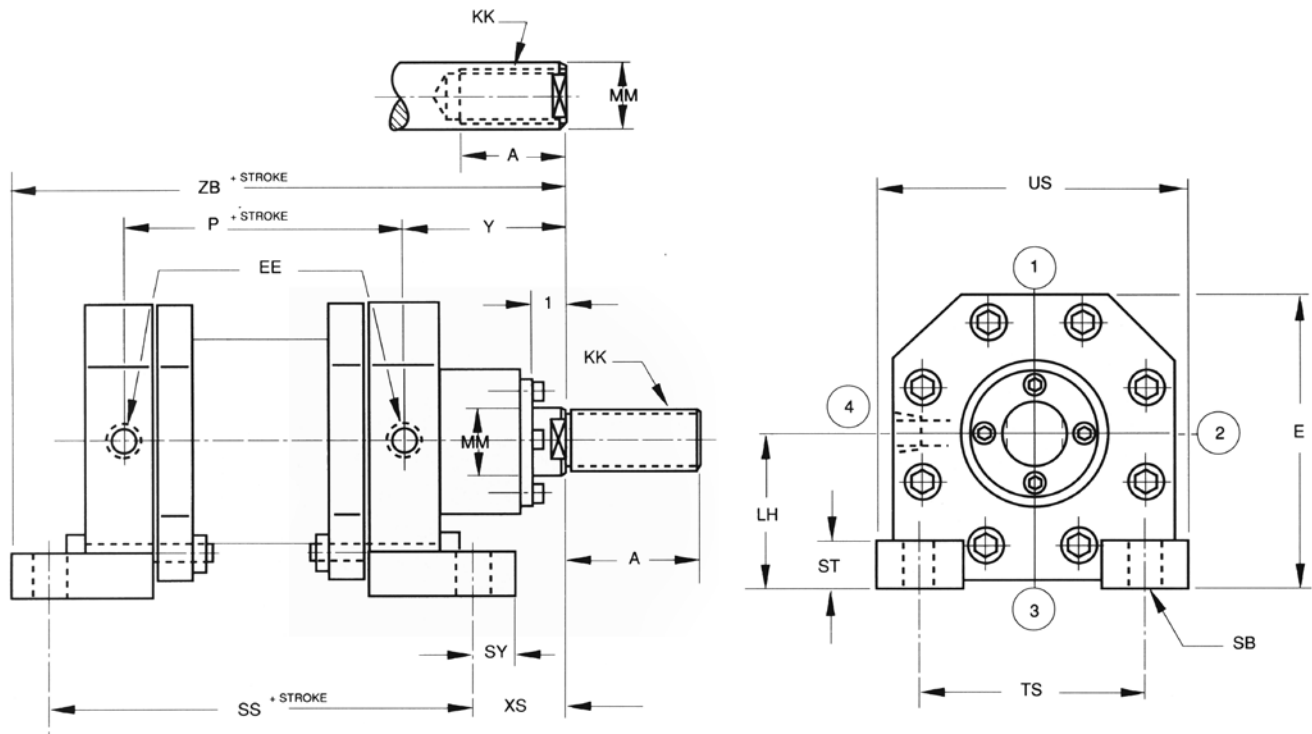

200 PSI Air Mill Cylinder Model MA02 BM

Model Number	Bore	MM	E	EE NPT	KK	LH	A	P	SB	SS	ST	SY	TS	US	XS	Y	ZB
MA02BM - 02A	2	1	3 1/2	1/2	3/4-16	1 7/8	1	3 5/8	17/32	6	5/8	1/2	4	5	1 5/16	2 1/2	7 13/16
MA02BM - 03A	3	1 3/8	5 1/8	1/2	1-14	2 3/4	1 3/8	4 1/4	21/32	7	3/4	5/8	4 5/8	5 7/8	1 3/4	3 1/8	9 3/8
MA02BM - 04A	4	1 3/4	6 9/16	1/2	1 1/4-12	3 3/8	1 3/4	4 1/2	25/32	7 5/8	7/8	3/4	5 7/8	7 3/8	1 13/16	3 3/8	10 3/16
MA02BM - 05A	5	2	7 11/16	3/4	1 1/2-12	4	2	5 3/8	29/32	8 1/2	1	7/8	5 3/4	7 1/2	2 1/8	3 11/16	11 1/2
MA02BM - 06A	6	2 1/2	8 15/16	3/4	1 7/8-12	4 1/2	2 1/2	6 1/8	11/32	9 7/8	1 1/4	1	6 5/8	8 5/8	2	3 7/8	12 7/8
MA02BM - 08A	8	2 1/2	10 1/8	3/4	1 7/8-12	5 1/8	2 1/2	3 3/4	13/16	7 3/8	1 1/8	3/4	8	10	1 15/16	3 3/4	10 1/16
MA02BM - 10A	10	3	12 1/8	3/4	2-12	6 1/8	3	4	11/16	8 1/8	1 3/8	1	9 1/2	12	2 1/8	4 3/16	11 1/4
MA02BM - 12A	12	3	14 5/8	1	2-12	7 3/8	3	4 3/8	11/16	8 7/8	1 3/8	1	12	14 1/2	2 1/16	4 5/16	11 15/16
MA02BM - 14A	14	3 1/2	17 3/8	1	2 1/2-12	8 3/4	3 1/2	4 5/8	15/16	9 7/8	1 5/8	1 1/4	14	17 1/4	2	4 5/8	13 1/8
MA02BM - 16A	16	3 1/2	19 3/8	1 1/4	2 1/2-12	9 3/4	3 1/2	5 1/8	15/16	10 5/8	1 5/8	1 1/4	16	19 1/4	2	4 3/4	13 7/8
MA02BM - 18A	18	4 1/4	21 7/8	1 1/4	3-12	11	4 1/4	5 3/8	19/16	11 5/8	1 7/8	1 1/2	18	21 3/4	2 3/8	5 1/2	15 1/2
MA02BM - 20A	20	4 1/4	23 7/8	1 1/2	3-12	12	4 1/4	5 7/8	19/16	12 3/8	1 7/8	1 1/2	20	23 3/4	2 3/8	5 5/8	16 1/4

Base Mount

2000 PSI Hyd. Mill Cylinder

Model MH01 BM

A - Standard Rod

B - Differential Rod

Model Number	Bore	MM	E	E E NPT	KK	LH	A	P	SB	SS	ST	SY	TS	US	XS	Y	ZB
MH01BM - 02A	2	1	3 1/2	1/2	3/4-16	1 7/8	1	3 5/8	17/32	6	5/8	1/2	4	5	1 5/16	2 1/2	7 13/16
MH01BM - 02B		1 3/8			1-14		1 3/8								1 11/16	2 7/8	8 3/16
MH01BM - 03A	3	1 3/8	5 1/8	3/4	1-14	2 3/4	1 3/8	4 1/4	21/32	7	1	5/8	5 5/8	6 7/8	1 3/4	3 1/8	9 3/8
MH01BM - 03B		2			1 1/2-12		2								2 1/8	3 1/2	9 3/4
MH01BM - 04A	4	1 3/4	6 9/16	3/4	1 1/4-12	3 3/8	1 3/4	4 1/2	25/32	7 5/8	7/8	3/4	6 3/8	7 7/8	1 13/16	3 3/8	10 3/16
MH01BM - 04B		2 1/2			1 7/8-12		2 1/2								2 5/16	3 7/8	10 11/16
MH01BM - 05A	5	2	7 11/16	1	1 1/2-12	4	2	5 3/8	29/32	8 1/2	1	7/8	7 5/8	9 3/8	2 1/8	3 11/16	11 1/2
MH01BM - 05B		3 1/2			2 1/2-12		3 1/2								3 1/4	4 13/16	12 5/8
MH01BM - 06A	6	2 1/2	8 15/16	1 1/4	1 7/8-12	4 1/2	2 1/2	6 1/8	1 1/32	9 7/8	1 1/4	1	8 3/4	10 3/4	2	3 7/8	12 7/8
MH01BM - 06B		4 1/4			3-12		4 1/4								3 1/2	5 3/8	14 3/8
MH01BM - 08A	8	3	11 7/16	1 1/4	2 1/4-12	5 13/16	3	7	1 5/32	10 5/8	1 3/8	1 1/8	10 3/4	13	2 11/16	4 1/2	14 7/16
MH01BM - 08B		5 3/4			4-12		5 3/4								4 13/16	6 5/8	16 9/16
MH01BM - 10A	10	3 1/2	15 1/8	1 1/2	2 1/2-12	7 5/8	3 1/2	8 5/8	1 5/16	12 5/8	1 5/8	1 1/4	11	13 1/2	3	5	16 7/8
MH01BM - 10B		5 3/4			4-12		5 3/4								4 3/4	6 3/4	18 5/8
MH01BM - 12A	12	4 1/4	18 1/8	1 1/2	3-12	9 1/8	4 1/4	9 1/2	1 9/16	14 1/8	1 7/8	1 1/2	13	16	3 7/16	5 3/4	19 1/16
MH01BM - 12B		5 3/4			4-12		5 3/4								4 7/16	6 3/4	20 1/16
MH01BM - 14A	14	5 3/4	20 1/2	2	4-12	10 1/2	5 3/4	10 5/8	1 13/16	19 7/8	2 1/8	1 3/4	16 1/2	20	2 3/8	7	24
MH01BM - 14B		7			5-12		7								3 1/8	7 3/4	24 3/4
MH01BM - 16A	16	5 3/4	22 1/2	2	4-12	11 1/2	5 3/4	11 5/8	2 1/16	22 3/8	2 3/8	2	18	22	1 5/8	7	26
MH01BM - 16B		7			5-12		7								2 3/8	7 3/4	26 3/4

3000 PSI Hyd. Mill Cylinder

Model MH31 BM

A - Standard Rod

B - Differential Rod

Model Number	Bore	MM	E	E E NPT	KK	LH	A	P	SB	SS	ST	SY	TS	US	XS	Y	ZB
MH31BM - 03A	3	1 3/4	6 1/8	3/4	1 1/4-12	3 5/8	1 3/4	6	11/16	11	7/8	5/8	5 1/4	6 1/2	3 1/4	5 3/4	14 7/8
MH31BM - 03B		2			1 1/2-12		2										
MH31BM - 04A	4	2	8 1/16	3/4	1 1/2-12	4 1/2	2	7	13/16	11 1/2	1	3/4	7	8 1/2	3 1/2	5 3/4	15 3/4
MH31BM - 04B		2 1/2			1 7/8-12		2 1/2										
MH31BM - 05A	5	2 1/2	9 3/8	1	1 7/8-12	5 1/8	2 1/2	7 15/16	1 1/16	13 5/8	1 1/2	1	7 1/2	9 1/2	3 1/2	6 11/32	18 1/8
MH31BM - 05B		3 1/2			2 1/2-12		3 1/2										
MH31BM - 06A	6	3	10 5/8	1 1/4	2 1/4-12	5 5/8	3	8 3/8	1 5/16	15 1/8	1 7/8	1 1/4	8	10 1/2	3 1/2	6 7/8	19 7/8
MH31BM - 06B		4 1/4			3-12		4 1/4										
MH31BM - 08A	8	4 1/4	14	1 1/4	3-12	7 1/2	4 1/4	9 1/4	1 9/16	16 3/4	2 1/4	1 1/2	11	14	4	7 3/4	22 1/4
MH31BM - 08B		5 3/4			4-12		5 3/4										
MH31BM - 10A	10	5	17 1/8	1 1/2	4-12	9	5	10 1/2	1 7/8	19 5/8	2 1/2	1 7/8	13	17 1/2	4	8 9/16	25 1/2
MH31BM - 10B		7			5-12		7										
MH31BM - 12A	12	5 3/4	20 3/4	1 1/2	4-12	11	5 3/4	11 3/8	2 3/8	20	2 3/4	2 1/4	15	21	4	8 5/16	26 1/4
MH31BM - 12B		8			5-12		8										
MH31BM - 14A	14	7	23 3/4	2	6-8	12 3/4	7	12 1/4	2 5/8	24	2 7/8	2 1/2	19	24	4 1/8	10	30 5/8
MH31BM - 14B		9			6-8		9										
MH31BM - 16A	16	8	26 3/4	2-30	7-8	14	8	13 5/8	3 1/8	26 1/2	2 7/8	3	21	27 1/2	4 1/4	10 11/16	33 3/4
MH31BM - 16B		10			7-8		10										

Trunnion Mount

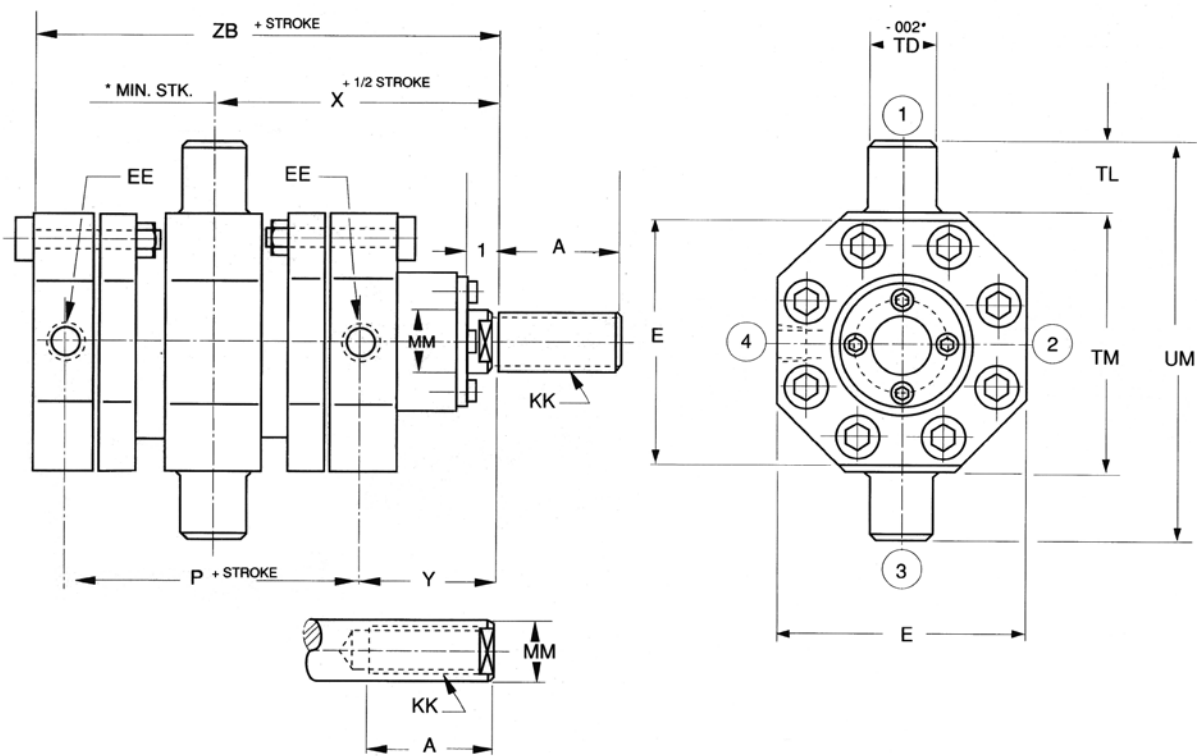

200 PSI Air Mill Cylinder Model MA02 TN

Model Number	Bore	MM	E	EE NPT	KK	A	P	TD	TL	TM	UM	X	Y	ZB	Min. Stroke
MA02TN - 02A	2	1	3 1/4	1/2	3/4-16	1	3 5/8	1 1/4	1 1/4	3 3/4	6 1/4	4 5/16	2 1/2	6 3/4	1 1/2
MA02TN - 03A	3	1 3/8	4 3/4	1/2	1-14	1 3/8	4 1/4	1 3/8	1 3/8	5 1/8	7 7/8	5 1/4	3 1/8	8 1/8	2 1/4
MA02TN - 04A	4	1 3/4	6 3/8	1/2	1 1/4-12	1 3/4	4 1/2	1 3/4	1 3/4	6 5/8	10 1/8	5 5/8	3 3/8	8 5/8	2 3/8
MA02TN - 05A	5	2	7 3/8	3/4	1 1/2-12	2	5 3/8	2	2	7 9/16	11 9/16	6 3/8	3 11/16	10	2 1/2
MA02TN - 06A	6	2 1/2	8 7/8	3/4	1 7/8-12	2 1/2	6 1/8	2 1/4	2 1/4	9 1/8	13 5/8	6 15/16	3 7/8	11 1/8	3 5/8
MA02TN - 08A	8	2 1/2	10	3/4	1 7/8-12	2 1/2	3 3/4	1 1/2	1 5/8	10 1/4	13 1/2	5 5/8	3 3/4	8 3/16	3
MA02TN - 10A	10	3	12	3/4	2-12	3	4	1 3/4	1 7/8	12 1/4	16	6 3/16	4 3/16	8 7/8	3
MA02TN - 12A	12	3	14 1/2	1	2-12	3	4 3/8	2	2 1/8	14 3/4	19	6 1/2	4 5/16	9 9/16	3 1/2
MA02TN - 14A	14	3 1/2	17 1/4	1	2 1/2-12	3 1/2	4 5/8	2 1/4	2 3/8	17 1/2	22 1/4	6 15/16	4 5/8	10 1/8	3 1/2
MA02TN - 16A	16	3 1/2	19 1/4	1 1/4	2 1/2-12	3 1/2	5 1/8	2 1/2	2 5/8	19 1/2	24 3/4	7 5/16	4 3/4	10 7/8	3 1/2
MA02TN - 18A	18	4 1/4	21 3/4	1 1/4	3-12	4 1/4	5 3/8	2 3/4	2 7/8	22	27 3/4	8 3/16	5 1/2	11 7/8	3 3/4
MA02TN - 20A	20	4 1/4	23 3/4	1 1/2	3-12	4 1/4	5 7/8	3	3 1/8	24	30 1/4	8 9/16	5 5/8	12 5/8	3 3/4

Trunnion Mount

2000 PSI Hyd. Mill Cylinder

Model MH01 TN

A - Standard Rod
B - Differential Rod

Model Number	Bore	MM	E	EE NPT	KK	A	P	TD	TL	TM	UM	X	Y	ZB	Min. Stroke
MH01TN - 02A	2	1	3 1/4	1/2	3/4-16	1	3 5/8	1 1/4	1 1/4	3 3/4	6 1/4	4 5/16	2 1/2	6 3/4	2 1/4
MH01TN - 02B		1 3/8			1-14	1 3/8						4 11/16	2 7/8	7 1/8	
MH01TN - 03A	3	1 3/8	4 3/4	3/4	1-14	1 3/8	4 1/4	1 3/8	1 3/8	5 1/8	7 7/8	5 1/4	3 1/8	8 1/8	2 1/2
MH01TN - 03B		2			1 1/2-12	2						5 5/8	3 1/2	8 1/2	
MH01TN - 04A	4	1 3/4	6 3/8	3/4	1 1/4-12	1 3/4	4 1/2	1 3/4	1 3/4	6 5/8	10 1/8	5 5/8	3 3/8	8 5/8	3
MH01TN - 04B		2 1/2			1 7/8-12	2 1/2						6 1/8	3 7/8	9 1/8	
MH01TN - 05A	5	2	7 3/8	1	1 1/2-12	2	5 3/8	2	2	7 9/16	11 9/16	6 3/8	3 11/16	10	3 1/2
MH01TN - 05B		3 1/2			2 1/2-12	3 1/2						7 1/2	4 13/16	11 1/8	
MH01TN - 06A	6	2 1/2	8 7/8	1 1/4	1 7/8-12	2 1/2	6 1/8	2 1/4	2 1/4	9 1/8	13 5/8	6 15/16	3 7/8	11 1/8	4
MH01TN - 06B		4 1/4			3-12	4 1/4						8 7/16	5 3/8	12 5/8	
MH01TN - 08A	8	3	11 1/4	1 1/4	2 1/4-12	3	7	2 1/2	2 1/2	11 7/16	16 7/16	8	4 1/2	12 5/8	5
MH01TN - 08B		5 3/4			4-12	5 3/4						10 1/8	6 5/8	14 3/4	
MH01TN - 10A	10	3 1/2	15	1 1/2	2 1/2-12	3 1/2	8 5/8	3	3	16 1/2	22 1/2	9 5/16	5	14 15/16	4 1/2
MH01TN - 10B		5 3/4			4-12	5 3/4						11 1/16	6 3/4	16 11/16	
MH01TN - 12A	12	4 1/4	18	1 1/2	3-12	4 1/4	9 1/2	3 1/2	3 1/2	19	26	10 1/2	5 3/4	16 9/16	5 7/8
MH01TN - 12B		5 3/4			4-12	5 3/4						11 1/2	6 3/4	17 9/16	
MH01TN - 14A	14	5 3/4	20	2	4-12	5 3/4	10 5/8	4 1/2	4 1/2	21 1/2	30 1/2	12 5/16	7	19 3/16	6 1/2
MH01TN - 14B		7			5-12	7						13 1/16	7 3/4	19 15/16	
MH01TN - 16A	16	5 3/4	22	2	4-12	5 3/4	11 5/8	5	5	23 1/2	33 1/2	12 13/16	7	20 3/16	5 3/4
MH01TN - 16B		7			5-12	7						13 9/16	7 3/4	20 15/16	

3000 PSI Hyd. Mill Cylinder

Model MH31 TN

A - Standard Rod
B - Differential Rod

Model Number	Bore	MM	E	EE NPT	KK	A	P	TD	TL	TM	UM	X	Y	ZB	Min. Stroke
MH31TN - 03A	3	1 3/4	5	3/4	1 1/4-12	1 3/4	6	1 1/2	1 5/8	6 1/2	9 3/4	8 3/4	5 3/4	12 9/16	1 1/2
MH31TN - 03B		2			1 1/2-12	2									
MH31TN - 04A	4	2	7 1/8	3/4	1 1/2-12	2	7	1 3/4	2 1/8	8 1/4	12 1/2	9 1/4	5 3/4	13 5/8	2
MH31TN - 04B		2 1/2			1 7/8-12	2 1/2									
MH31TN - 05A	5	2 1/2	8 1/2	1	1 7/8-12	2 1/2	7 15/16	2 1/4	2 5/8	9 3/4	15	10 5/16	6 11/32	15 5/16	2 3/8
MH31TN - 05B		3 1/2			2 1/2-12	3 1/2									
MH31TN - 06A	6	3	10	1 1/4	2 1/4-12	3	8 3/8	2 1/2	3	10 3/4	16 3/4	11 1/16	6 7/8	16 7/16	3 1/4
MH31TN - 06B		4 1/4			3-12	4 1/4									
MH31TN - 08A	8	4 1/4	13	1 1/4	3-12	4 1/4	9 1/4	3 1/2	4 1/4	14 1/2	23	12 3/8	7 3/4	18 1/2	4 3/4
MH31TN - 08B		5 3/4			4-12	5 3/4									
MH31TN - 10A	10	5	16 1/4	1 1/2	4-12	5	10 1/2	4	5 1/4	18	28 1/2	13 13/16	8 9/16	20 9/16	6
MH31TN - 10B		7			5-12	7									
MH31TN - 12A	12	5 3/4	19 1/2	1 1/2	4-12	5 3/4	11 3/8	5	6 1/4	20 1/2	33	14	8 5/16	21 3/8	7 3/4
MH31TN - 12B		8			5-12	8									
MH31TN - 14A	14	7	22	2	6-8	7	12 1/4	5 1/2	6 3/4	23	36 1/2	16 1/8	10	24 1/16	8 5/8
MH31TN - 14B		9			6-8	9									
MH31TN - 16A	16	8	25 1/2	2	7-8	8	13 5/8	6 1/2	7 1/4	26 1/2	41	17 1/2	10 11/16	26 3/8	9 1/2
MH31TN - 16B		10			7-8	10									

Front Flange Mount

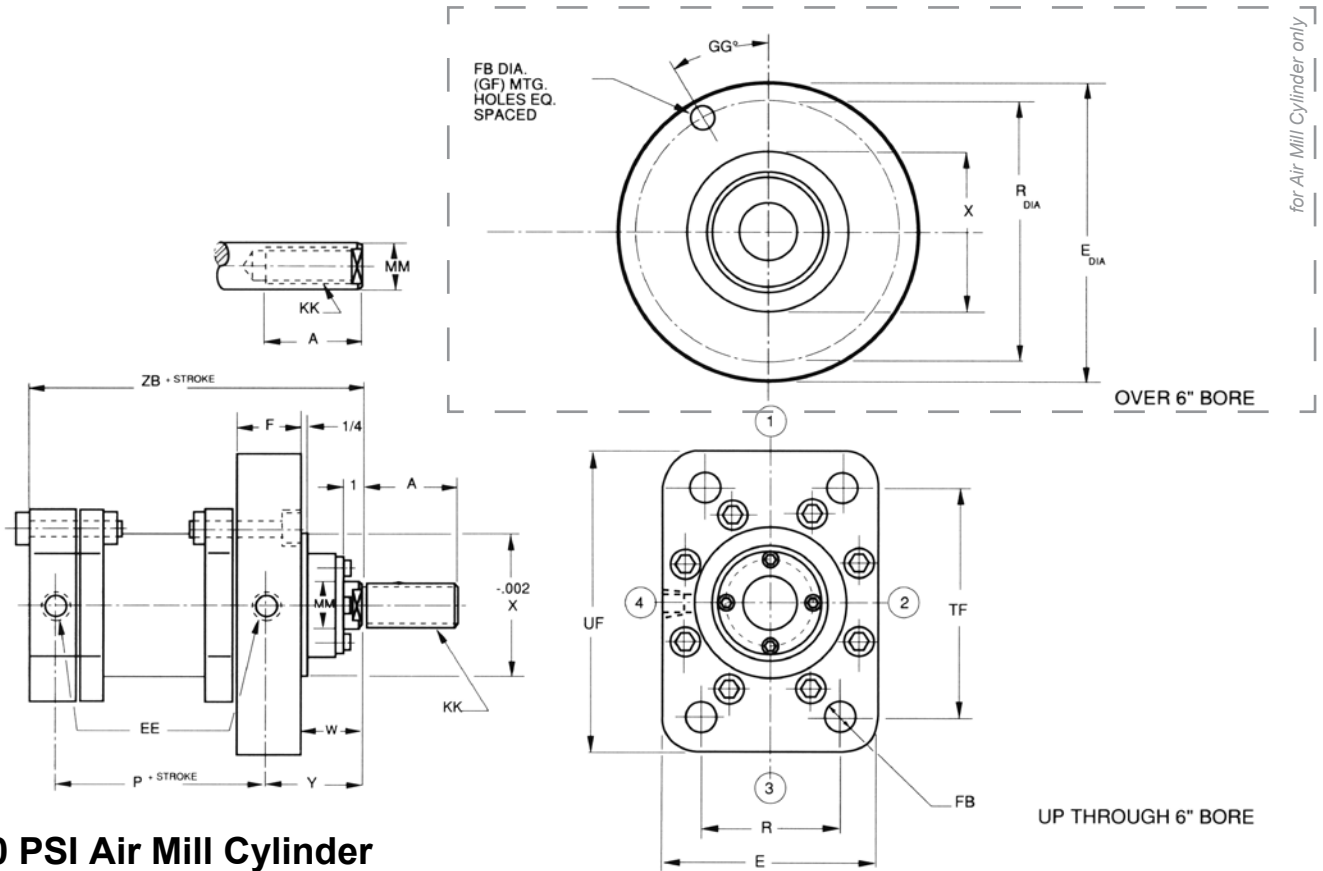

200 PSI Air Mill Cylinder Model MA02 FF

Model Number	Bore	MM	E & E DIA	E E NPT	F	FB	GF	GG	KK	A	P	R & R DIA	TF	UF	W	X	Y	ZB
MA02FF - 02A	2	1	3 1/2	1/2	1 3/8	13/32	-	-	3/4-16	1	3 5/8	2 1/2	4 1/4	5 1/8	1 7/8	2 7/8	2 1/2	6 3/4
MA02FF - 03A	3	1 3/8	4 3/4	1/2	1 5/8	21/32	-	-	1-14	1 3/8	4 1/4	3 3/8	5 3/4	7 1/8	2 3/8	3 5/8	3 1/8	8 1/8
MA02FF - 04A	4	1 3/4	6 3/8	1/2	1 5/8	25/32	-	-	1 1/4-12	1 3/4	4 1/2	4 3/4	7 1/4	8 7/8	2 5/8	4 3/8	3 3/8	8 5/8
MA02FF - 05A	5	2	7 3/8	3/4	2	1 1/32	-	-	1 1/2-12	2	5 3/8	5 5/8	8 1/2	10 1/4	2 3/4	5 3/8	11 1/16	10
MA02FF - 06A	6	2 1/2	8 7/8	3/4	2 3/8	19/32	-	-	1 7/8-12	2 1/2	6 1/8	5 7/8	10 1/4	13 1/4	2 3/4	5	3 7/8	11 1/8
MA02FF - 08A	8	2 1/2	13 1/2	3/4	1 7/8	11/16	6	30°	1 7/8-12	2 1/2	3 3/4	12 1/4	-	-	2 7/8	8 3/4	3 3/4	8 3/8
MA02FF - 10A	10	3	16	3/4	1 7/8	13/16	6	30°	2-12	3	4	14 1/2	-	-	3 5/16	10	4 3/16	9 1/16
MA02FF - 12A	12	3	18 1/4	1	2 1/8	13/16	8	22 1/2°	2-12	3	4 3/8	16 3/4	-	-	3 1/4	12	4 5/16	9 3/4
MA02FF - 14A	14	3 1/2	22	1	2 1/8	1 1/16	8	22 1/2°	2 1/2-12	3 1/2	4 5/8	20	-	-	3 9/16	13	4 5/8	10 5/16
MA02FF - 16A	16	3 1/2	24	1 1/4	2 3/8	1 1/16	12	15°	2 1/2-12	3 1/2	5 1/8	22	-	-	3 9/16	14 1/4	4 3/4	11 1/16
MA02FF - 18A	18	4 1/4	26 1/2	1 1/4	2 3/8	1 1/16	12	15°	3-12	4 1/4	5 3/8	24 1/2	-	-	4 5/16	14 1/4	5 1/2	12 1/16
MA02FF - 20A	20	4 1/4	28 1/2	1 1/2	2 3/4	1/16	12	15°	3-12	4 1/4	5 7/8	26 1/2	-	-	4 3/16	14 1/4	5 5/8	12 15/16

Front Flange Mount

2000 PSI Hyd. Mill Cylinder

Model MH01 FF

A - Standard Rod

B - Differential Rod

Model Number	Bore	MM	E	E E NPT	F	FB	KK	A	P	R	TF	UF	W	X	Y	ZB
MH01FF - 02A	2	1	3 1/4	1/2	1 3/8	13/32	3/4-16	1	3 5/8	2 1/2	4 1/4	5 1/8	1 7/8	2 7/8	2 1/2	6 3/4
MH01FF - 02B		1 3/8					1-14	1 3/8				2 1/4	3 1/8	2 7/8		7 1/8
MH01FF - 03A	3	1 3/8	4 3/4	3/4	1 5/8	21/32	1-14	1 3/8	4 1/4	3 3/8	5 3/4	7 1/8	2 3/8	3 5/8	3 1/8	8 1/8
MH01FF - 03B		2					1 1/2-12	2				2 3/4	4 5/8	3 1/2		8 1/2
MH01FF - 04A	4	1 3/4	6 3/8	3/4	1 5/8	25/32	1 1/4-12	1 3/4	4 1/2	4 3/4	7 1/4	8 7/8	2 5/8	4 3/8	3 3/8	8 5/8
MH01FF - 04B		2 1/2					1 7/8-12	2 1/2				3 1/8	5 5/8	3 7/8		9 1/8
MH01FF - 05A	5	2	7 3/8	1	2	1 1/32	1 1/2-12	2	5 3/8	5 5/8	8 1/2	10 1/4	2 3/4	5	3 11/16	10
MH01FF - 05B		3 1/2					2 1/2-12	3 1/2				3 7/8	6 3/8	4 13/16		11 1/8
MH01FF - 06A	6	2 1/2	8 7/8	1 1/4	2 3/8	19/32	1 7/8-12	2 1/2	6 1/8	5 7/8	10 1/4	13 1/4	2 3/4	5	3 7/8	11 1/8
MH01FF - 06B		4 1/4					3-12	4 1/4				4 1/4	7 1/2	5 3/8		12 5/8
MH01FF - 08A	8	3	11 1/4	1 1/4	2 3/8	19/16	2 1/4-12	3	7	8 1/2	12 1/2	15 1/4	3 3/8	8	4 1/2	12 5/8
MH01FF - 08B		5 3/4					4-12	5 3/4				5 1/2	9 1/2	6 5/8		14 3/4
MH01FF - 10A	10	3 1/2	15	1 1/2	2 3/4	1 13/16	2 1/2-12	3 1/2	8 5/8	11 1/2	15 1/2	19	3 11/16	10	5	14 15/16
MH01FF - 10B		5 3/4					4-12	5 3/4				5 7/16	10	6 3/4		16 11/16
MH01FF - 12A	12	4 1/4	18	1 1/2	2 3/4	2 1/16	3-12	4 1/4	9 1/2	14 1/2	17 1/2	21	4 7/16	12	5 3/4	16 9/16
MH01FF - 12B		5 3/4					4-12	5 3/4				5 7/16	12	6 3/4		17 9/16
MH01FF - 14A	14	5 3/4	20	2	3 1/8	2 1/16	4-12	5 3/4	10 5/8	16	20	24	5 7/16	13	7	19 3/16
MH01FF - 14B		7					5-12	7				6 3/16	13	7 3/4		19 15/16
MH01FF - 16A	16	5 3/4	22	2	3 1/8	2 9/16	4-12	5 3/4	11 5/8	17 1/2	21	25 1/2	5 7/16	14 1/4	7	20 3/16
MH01FF - 16B		7					5-12	7				6 3/16	14 1/4	7 3/4		20 15/16

3000 PSI Hyd. Mill Cylinder

Model MH31 FF

A - Standard Rod

B - Differential Rod

Model Number	Bore	MM	E	E E NPT	F	FB	KK	A	P	R	TF	UF	W	X	Y	ZB
MH31FF - 03A	3	1 3/4	6 1/4	3/4	2 1/4	15/16	1 1/4-12	1 3/4	6	4 1/2	6 3/4	8 1/2	3 1/2	4 3/4	5	11 13/16
MH31FF - 03B		2					1 1/2-12	2								
MH31FF - 04A	4	2	8	3/4	2 3/4	1 5/16	1 1/2-12	2	7	5 1/2	8 3/4	11 1/4	3 1/4	6	5 1/8	13
MH31FF - 04B		2 1/2					1 7/8-12	2 1/2								
MH31FF - 05A	5	2 1/2	9 1/4	1	3	1 9/16	1 7/8-12	2 1/2	7 15/16	6	10 1/2	13 1/2	3 1/2	6 3/4	5 15/32	14 7/16
MH31FF - 05B		3 1/2					2 1/2-12	3 1/2								
MH31FF - 06A	6	3	10 1/4	1 1/4	3 1/4	1 13/16	2 1/4-12	3	8 3/8	7	12 3/4	16 1/4	3 3/4	7 1/2	5 13/16	15 3/8
MH31FF - 06B		4 1/4					3-12	4 1/4								
MH31FF - 08A	8	4 1/4	14	1 1/4	3 3/4	2 5/8	3-12	4 1/4	9 1/4	9	16 3/4	21 3/4	4 1/4	10	6 3/4	17 1/2
MH31FF - 08B		5 3/4					4-12	5 3/4								
MH31FF - 10A	10	5	17	1 1/2	4 1/2	2 5/8	4-12	5	10 1/2	12	18 1/2	23 1/2	4 1/2	11 1/2	7 1/2	19 1/2
MH31FF - 10B		7					5-12	7								
MH31FF - 12A	12	5 3/4	19 1/2	1 1/2	5	3 1/8	4-12	5 3/4	11 3/8	13 1/2	22	28	4	13	7 5/16	20 3/8
MH31FF - 12B		8					5-12	8								
MH31FF - 14A	14	7	22	2	5 1/2	3 5/8	6-8	7	12 1/4	15	25	32	5 1/2	14 1/2	9 3/16	23 1/4
MH31FF - 14B		9					6-8	9								
MH31FF - 16A	16	8	25 1/2	2	6	4 1/8	7-8	8	13 5/8	17 1/2	29	37	6	15 3/4	9 15/16	25 5/8
MH31FF - 16B		10					7-8	10								

Rear Flange Mount

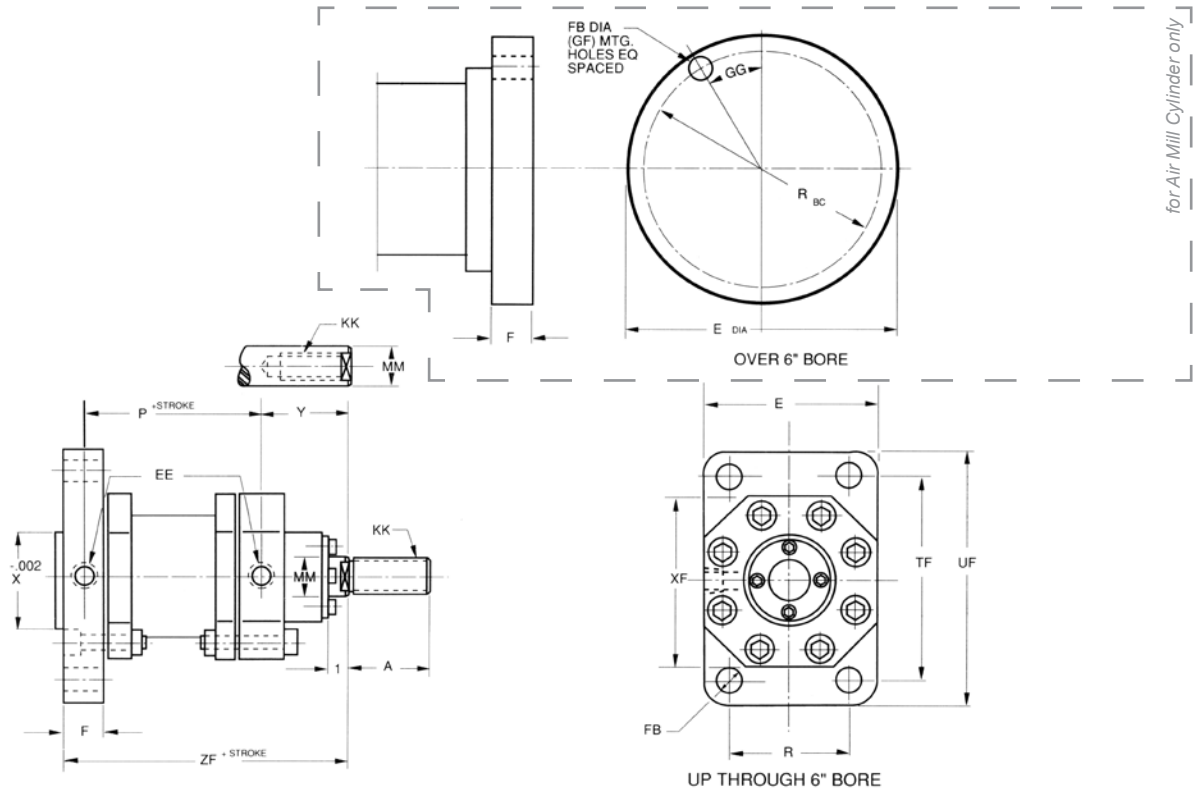

200 PSI Air Mill Cylinder Model MA02 RF

Model Number	Bore	MM	E & E DIA	E E NPT	F	FB	GF	GG	KK	A	P	R & R BC	TF	UF	X	XF	Y	ZF
MA02RF - 02A	2	1	3 1/4	1/2	1 3/8	13/32	-	-	3/4-16	1	3 5/8	2 1/2	4 1/4	5 1/8	2	3 1/4	2 1/2	6 3/4
MA02RF - 03A	3	1 3/8	4 3/4	1/2	1 5/8	21/32	-	-	1-14	1 3/8	4 1/4	3 3/8	5 3/4	7 1/8	3 5/8	4 3/4	3 1/8	8 1/8
MA02RF - 04A	4	1 3/4	6 3/8	1/2	1 5/8	25/32	-	-	1 1/4-12	1 3/4	4 1/2	4 3/4	7 1/4	8 7/8	4 3/8	6 3/8	3 3/8	8 5/8
MA02RF - 05A	5	2	7 3/8	3/4	2	1 1/32	-	-	1 1/2-12	2	5 3/8	5 5/8	8 1/2	10 1/4	5	7 3/8	3 11/16	10
MA02RF - 06A	6	2 1/2	8 7/8	3/4	2 3/8	19/32	-	-	1 7/8-12	2 1/2	6 1/8	5 7/8	10 1/4	13 1/4	6	8 7/8	3 7/8	11 1/8
MA02RF - 08A	8	2 1/2	13 1/2	3/4	1 7/8	11/16	6	30°	1 7/8-12	2 1/2	3 3/4	12 1/4	-	-	-	10	3 3/4	8 3/8
MA02RF - 10A	10	3	16	3/4	1 7/8	13/16	6	30°	2-12	3	4	14 1/2	-	-	-	12	4 3/16	9 1/16
MA02RF - 12A	12	3	18 1/4	1	2 1/8	13/16	8	22 1/2°	2-12	3	4 3/8	16 3/4	-	-	-	14 1/2	4 5/16	9 3/4
MA02RF - 14A	14	3 1/2	22	1	2 1/8	1 1/16	8	22 1/2°	2 1/2-12	3 1/2	4 5/8	20	-	-	-	17 1/4	4 5/8	10 5/16
MA02RF - 16A	16	3 1/2	24	1 1/4	2 3/8	1 1/16	12	15°	2 1/2-12	3 1/2	5 1/8	22	-	-	-	19 1/4	4 3/4	11 1/16
MA02RF - 18A	18	4 1/4	26 1/2	1 1/4	2 3/8	1 1/16	12	15°	3-12	4 1/4	5 3/8	24 1/2	-	-	-	21 3/4	5 1/2	12 1/16
MA02RF - 20A	20	4 1/4	28 1/2	1 1/2	2 3/4	1 1/16	12	15°	3-12	4 1/4	5 7/8	26 1/2	-	-	-	23 3/4	5 5/8	12 15/16

Rear Flange Mount

2000 PSI Hyd. Mill Cylinder

Model MH01 RF

A - Standard Rod

B - Differential Rod

Model Number	Bore	MM	E	E E SAE	F	FB	KK	A	P	R	TF	UF	X	Y	ZF
MH01RF - 02A	2	1	3 1/4	1/2-8	1 3/8	13/32	3/4-16	1	3 5/8	2 1/2	4 1/4	5 1/8	2	2 1/2	6 3/4
MH01RF - 02B		1 3/8					1-14	1 3/8						2 7/8	7 1/8
MH01RF - 03A	3	1 3/8	4 3/4	3/4-12	1 5/8	21/32	1-14	1 3/8	4 1/4	3 3/8	5 3/4	7 1/8	3 5/8	3 1/8	8 1/8
MH01RF - 03B		2					1 1/2-12	2						3 1/2	8 1/2
MH01RF - 04A	4	1 3/4	6 3/8	3/4-12	1 5/8	25/32	1 1/2-12	1 3/4	4 1/2	4 3/4	7 1/4	8 7/8	4 3/8	3 3/8	8 5/8
MH01RF - 04B		2 1/2					1 7/8-12	2 1/2						3 7/8	9 1/8
MH01RF - 05A	5	2	7 3/8	1-16	2	1 1/32	1 1/2-12	2	5 3/8	5 5/8	8 1/2	10 1/4	5	3 11/16	10
MH01RF - 05B		3 1/2					2 1/2-12	3 1/2						4 13/16	11 1/8
MH01RF - 06A	6	2 1/2	8 7/8	1 1/4-20	2 3/8	1 9/32	1 7/8-12	2 1/2	6 1/8	5 7/8	10 1/4	13 1/4	6	3 7/8	11 1/8
MH01RF - 06B		4 1/4					3-12	4 1/4						5 3/8	12 5/8
MH01RF - 08A	8	3	11 1/4	1 1/4-20	2 3/8	1 9/16	2 1/4-12	3	7	8 1/2	12 1/2	15 1/4	8	4 1/2	12 5/8
MH01RF - 08B		5 3/4					4-12	5 3/4						6 5/8	14 3/4
MH01RF - 10A	10	3 1/2	15	1 1/2-24	2 3/4	1 13/16	2 1/2-12	3 1/2	8 5/8	11 1/2	15 1/2	19	10	5	14 15/16
MH01RF - 10B		5 3/4					4-12	5 3/4						6 3/4	16 11/16
MH01RF - 12A	12	4 1/4	18	1 1/2-24	2 3/4	2 1/16	3-12	4 1/4	9 1/2	14 1/2	17 1/2	21	12	5 3/4	16 9/16
MH01RF - 12B		5 3/4					4-12	5 3/4						6 3/4	17 9/16
MH01RF - 14A	14	5 3/4	20	2-32	3 1/8	2 1/16	4-12	5 3/4	10 5/8	16	20	24	13	7	19 3/16
MH01RF - 14B		7					5-12	7						7 3/4	19 15/16
MH01RF - 16A	16	5 3/4	22	2-32	3 1/8	2 9/16	4-12	5 3/4	11 5/8	17 1/2	21	25 1/2	14 1/4	7	20 3/16
MH01RF - 16B		7					5-12	7						7 3/4	20 15/16

3000 PSI Hyd. Mill Cylinder

Model MH31 RF

A - Standard Rod

B - Differential Rod

Model Number	Bore	MM	E	E E NPT	F	FB	KK	A	P	R	TF	UF	X	XF	Y	ZF
MH31RF - 03A	3	1 3/4	6 1/4	3/4	2	15/16	1 1/4-12	1 3/4	6	4 1/2	6 3/4	8 1/2	3 5/8	5	5 3/4	13
MH31RF - 03B		2					1 1/2-12	2								
MH31RF - 04A	4	2	8	3/4	2	1 5/16	1 1/2-12	2	7	5 1/2	8 3/4	11 1/4	4 1/2	7 1/8	5 3/4	13 7/8
MH31RF - 04B		2 1/2					1 7/8-12	2 1/2								
MH31RF - 05A	5	2 1/2	9 1/4	1	2 3/8	1 9/16	1 7/8-12	2 1/2	7 15/16	6	10 1/2	13 1/2	5 3/4	8 1/2	6 11/32	15 5/8
MH31RF - 05B		3 1/2					2 1/2-12	3 1/2								
MH31RF - 06A	6	3	10 1/4	1 1/4	2 5/8	1 13/16	2 1/4-12	3	8 3/8	7	12 3/4	16 1/4	6 1/2	10	6 7/8	16 11/16
MH31RF - 06B		4 1/4					3-12	4 1/4								
MH31RF - 08A	8	4 1/4	14	1 1/4	3	2 5/8	3-12	4 1/4	9 1/4	9	16 3/4	21 3/4	8 3/4	13	7 3/4	18 3/4
MH31RF - 08B		5 3/4					4-12	5 3/4								
MH31RF - 10A	10	5	17	1 1/2	3 7/8	2 5/8	4-12	5	10 1/2	12	18 1/2	23 1/2	10	16 1/4	8 9/16	21 7/16
MH31RF - 10B		7					5-12	7								
MH31RF - 12A	12	5 3/4	19 1/2	1 1/2	3 7/8	3 1/8	4-12	5 3/4	11 3/8	13 1/2	22	28	11 1/2	19 1/2	8 5/16	21 7/8
MH31RF - 12B		8					5-12	8								
MH31RF - 14A	14	7	22	2	4 3/8	3 5/8	6-8	7	12 1/4	15	25	32	13	22	10	24 13/16
MH31RF - 14B		9					6-8	9								
MH31RF - 16A	16	8	25 1/2	2	4 3/4	4 1/8	7-8	8	13 5/8	17 1/2	29	37	14 1/4	25 1/2	10 11/16	26 5/8
MH31RF - 16B		10					7-8	10								

Male Clevis Mount

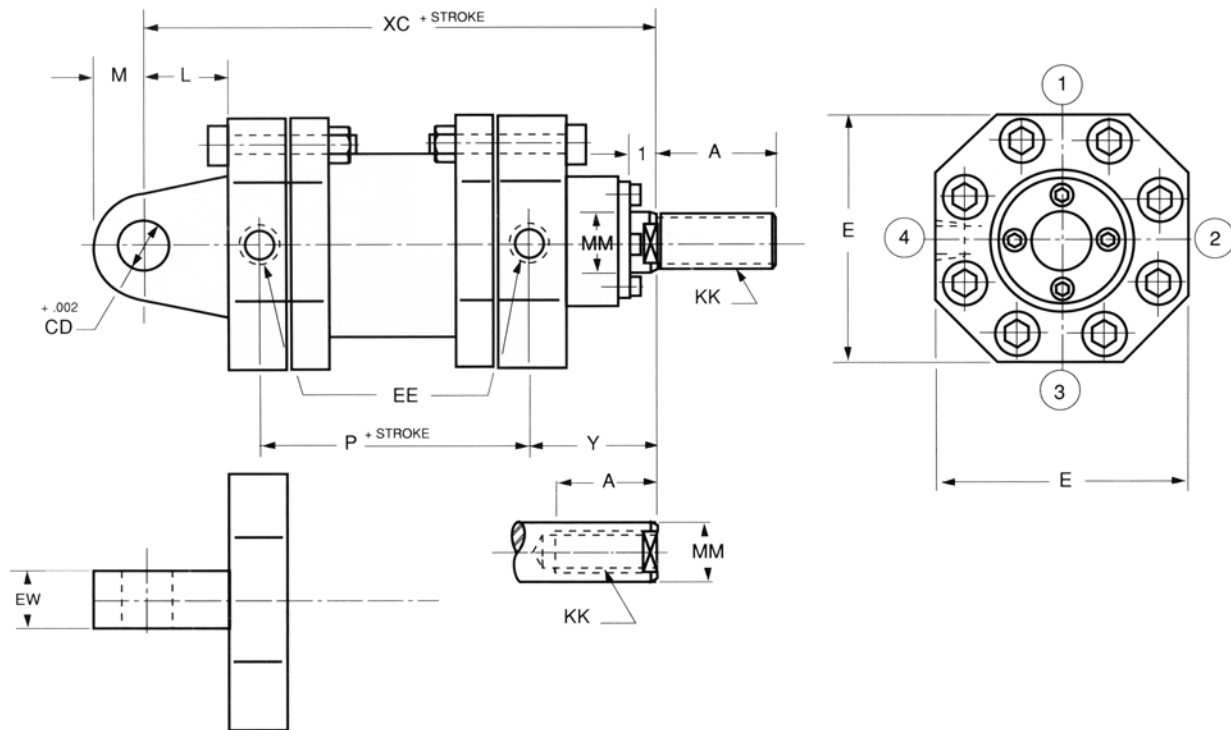

200 PSI Air Mill Cylinder Model MA02 MC

Model Number	Bore	MM	EB	CD	E	E E NPT	KK	L	M	A	P	Y	XC
MA02MC - 02A	2	1	1 1/4	3/4	3 1/4	1/2	3/4-16	1 3/8	3/4	1	3 5/8	2 1/2	8 1/8
MA02MC - 03A	3	1 3/8	1 1/2	1	4 3/4	1/2	1-14	1 5/8	1 1/8	1 3/8	4 1/4	3 1/8	9 3/4
MA02MC - 04A	4	1 3/4	2	1 3/8	6 3/4	1/2	1 1/4-12	1 7/8	1 1/4	1 3/4	4 1/2	3 3/8	10 1/2
MA02MC - 05A	5	2	2	1 3/8	7 3/8	3/4	1 1/2-12	2 1/8	1 3/8	2	5 3/8	3 11/16	12 1/8
MA02MC - 06A	6	2 1/2	2 1/2	1 3/4	8 7/8	3/4	1 7/8-12	2 5/8	1 5/8	2 1/2	6 1/8	3 7/8	13 3/4
MA02MC - 08A	8	2 1/2	3	1 3/4	10	3/4	1 7/8-12	2 5/16	1 3/4	2 1/2	3 3/4	3 3/4	10 1/2
MA02MC - 10A	10	3	3 1/2	2	12	3/4	2-12	2 5/8	2	3	4	4 3/16	11 1/2
MA02MC - 12A	12	3	3 1/2	2	14 1/2	1	2-12	2 5/8	2	3	4 3/8	4 5/16	12 3/16
MA02MC - 14A	14	3 1/2	4	2 1/2	17 1/4	1	2 1/2-12	3 1/4	2 1/2	3 1/2	4 5/8	4 5/8	13 3/8
MA02MC - 16A	16	3 1/2	4	2 1/2	19 1/4	1 1/4	2 1/2-12	3 1/4	2 1/2	3 1/2	5 1/8	4 3/4	14 1/8
MA02MC - 18A	18	4 1/4	5	3	21 3/4	1 1/4	3-12	3 3/4	3	4 1/4	5 3/8	5 1/2	15 5/8
MA02MC - 20A	20	4 1/4	5	3	23 3/4	1 1/2	3-12	3 3/4	3	4 1/4	5 7/8	5 5/8	16 3/8

Male Clevis Mount

2000 PSI Hyd. Mill Cylinder

Model MH01 MC

A - Standard Rod

B - Differential Rod

Model Number	Bore	MM	EW	CD	E	E E NPT	KK	L	M	A	P	Y	XC
MH01MC - 02A	2	1	1 1/4	3/4	3 1/4	1/2	3/4-16	1 3/8	3/4	1	3 5/8	2 1/2	8 1/8
MH01MC - 02B		1 3/8					1-14			1 3/8		2 7/8	8 1/2
MH01MC - 03A	3	1 3/8	1 1/2	1	4 3/4	3/4	1-14	1 5/8	1 1/8	1 3/8	4 1/4	3 1/8	9 3/4
MH01MC - 03B		2					1 1/2-12			2		3 1/2	10 1/8
MH01MC - 04A	4	1 3/4	2	1 3/8	6 3/8	3/4	1 1/4-12	1 7/8	1 1/4	1 3/4	4 1/2	3 3/8	10 1/2
MH01MC - 04B		2 1/2					1 7/8-12			2 1/2		3 7/8	11
MH01MC - 05A	5	2	2 1/2	1 3/4	7 3/8	1	1 1/2-12	2 1/8	1 3/8	2	5 3/8	3 11/16	12 1/8
MH01MC - 05B		3 1/2					2 1/2-12			3 1/2		4 13/16	13 1/4
MH01MC - 06A	6	2 1/2	2 1/2	2	8 7/8	1 1/4	1 7/8-12	2 5/8	1 5/8	2 1/2	6 1/8	3 7/8	13 3/4
MH01MC - 06B		4 1/4					3-12			4 1/4		5 3/8	15 1/4
MH01MC - 08A	8	3	3	2	11 1/4	1 1/4	2 1/4-12	3 3/16	1 7/8	3	7	4 1/2	15 13/16
MH01MC - 08B		5 3/4					4-12			5 3/4		6 5/8	17 15/16
MH01MC - 10A	10	3 1/2	3 1/2	2 1/2	15	1 1/2	2 1/2-12	3 11/16	2 3/8	3 1/2	8 5/8	5	18 5/8
MH01MC - 10B		5 3/4					4-12			5 3/4		6 3/4	20 3/8
MH01MC - 12A	12	4 1/4	4 1/2	3	18	1 1/2	3-12	4 3/16	2 7/8	4 1/4	9 1/2	5 3/4	20 3/4
MH01MC - 12B		5 3/4					4-12			5 3/4		6 3/4	21 3/4
MH01MC - 14A	14	5 3/4	5	3 1/2	20	2	4-12	5	3 3/8	5 3/4	10 5/8	7	24 3/16
MH01MC - 14B		7					5-12			7		7 3/4	24 15/16
MH01MC - 16A	16	5 3/4	6	4 1/4	22	2	4-12	5 1/2	4	5 3/4	11 5/8	7	25 11/16
MH01MC - 16B		7					5-12			7		7 3/4	26 7/16

3000 PSI Hyd. Mill Cylinder

Model MH31 MC

A - Standard Rod

B - Differential Rod

Model Number	Bore	MM	EW	CD	E	E E NPT	KK	L	M	A	P	Y	XC
MH31MC - 03A	3	1 3/4	2	1 3/8	5	3/4	1 1/4-12	2 7/16	1 1/4	1 3/4	6	5 3/4	15
MH31MC - 03B		2					1 1/2-12			2			
MH31MC - 04A	4	2	2 1/2	1 3/4	7 1/8	3/4	1 1/2-12	3	1 5/8	2	7	5 3/4	16 5/8
MH31MC - 04B		2 1/2					1 7/8-12			2 1/2			
MH31MC - 05A	5	2 1/2	2 1/2	2	8 1/2	1	1 7/8-12	3 7/16	2	2 1/2	7 15/16	6 11/32	18 3/4
MH31MC - 05B		3 1/2					2 1/2-12			3 1/2			
MH31MC - 06A	6	3	3	2	10	1 1/4	2 1/4-12	3 13/16	1 7/8	3	8 3/8	6 7/8	20 1/4
MH31MC - 06B		4 1/4					3-12			4 1/4			
MH31MC - 08A	8	4 1/4	4 1/2	3 1/2	13	1 1/4	3-12	5 1/2	4	4 1/4	9 1/4	7 3/4	23 3/4
MH31MC - 08B		5 3/4					4-12			5 3/4			
MH31MC - 10A	10	5	5 1/2	4	16 1/4	1 1/2	4-12	5 13/16	4 1/2	5	10 1/2	8 9/16	26 3/8
MH31MC - 10B		7					5-12			7			
MH31MC - 12A	12	5 3/4	6 1/2	5	19 1/2	1 1/2	4-12	6 3/4	5 1/2	5 3/4	11 3/8	8 5/16	28 1/8
MH31MC - 12B		8					5-12			8			
MH31MC - 14A	14	7	8	5 1/2	22	2	6-8	7 5/16	6	7	12 1/4	10	31 3/8
MH31MC - 14B		9					6-8			9			
MH31MC - 16A	16	8	9 1/2	6 1/2	25 1/2	2	7-8	8 1/4	7	8	13 5/8	10 11/16	34 5/8
MH31MC - 16B		10					7-8			10			

Female Clevis Mount

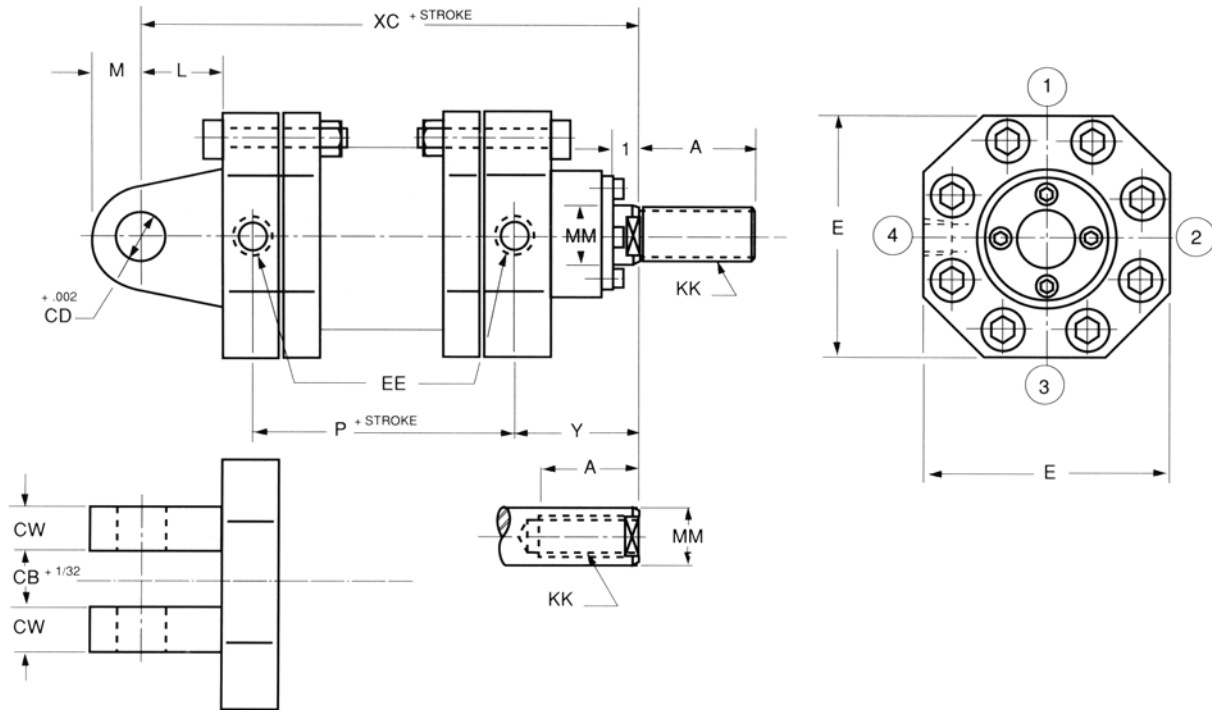

200 PSI Air Mill Cylinder Model MA02 FC

Model Number	Bore	MM	CB	CD	CW	E	EE NPT	KK	L	M	A	P	Y	XC
MA02FC - 02A	2	1	1 1/4	3/4	5/8	3 1/4	1/2	3/4-16	1 3/8	3/4	1	3 5/8	2 1/2	8 1/8
MA02FC - 03A	3	1 3/8	1 1/2	1	3/4	4 3/4	1/2	1-14	1 5/8	1 1/8	1 3/8	4 1/4	3 1/8	9 3/4
MA02FC - 04A	4	1 3/4	2	1 3/8	1	6 3/4	1/2	1 1/4-12	1 7/8	1 1/4	1 3/4	4 1/2	3 3/8	10 1/2
MA02FC - 05A	5	2	2	1 3/8	1 1/4	7 3/8	3/4	1 1/2-12	2 1/8	1 3/8	2	5 3/8	3 11/16	12 1/8
MA02FC - 06A	6	2 1/2	2 1/2	1 3/4	1 1/4	8 7/8	3/4	1 7/8-12	2 5/8	1 5/8	2 1/2	6 1/8	3 7/8	13 3/4
MA02FC - 08A	8	2 1/2	3	1 3/4	1 1/2	10	3/4	1 7/8-12	2 5/16	1 3/4	2 1/2	3 3/4	3 3/4	10 1/2
MA02FC - 10A	10	3	3 1/2	2	1 3/4	12	3/4	2-12	2 5/8	2	3	4	4 3/16	11 1/2
MA02FC - 12A	12	3	3 1/2	2	1 3/4	14 1/2	1	2-12	2 5/8	2	3	4 3/8	4 5/16	12 3/16
MA02FC - 14A	14	3 1/2	4	2 1/2	2	17 1/4	1	2 1/2-12	3 1/4	2 1/2	3 1/2	4 5/8	4 5/8	13 3/8
MA02FC - 16A	16	3 1/2	4	2 1/2	2	19 1/4	1 1/4	2 1/2-12	3 1/4	2 1/2	3 1/2	5 1/8	4 3/4	14 1/8
MA02FC - 18A	18	4 1/4	5	3	2 1/2	21 3/4	1 1/4	3-12	3 3/4	3	4 1/4	5 3/8	5 1/2	15 5/8
MA02FC - 20A	20	4 1/4	5	3	2 1/2	23 3/4	1 1/2	3-12	3 3/4	3	4 1/4	5 7/8	5 5/8	16 3/8

Female Clevis Mount

2000 PSI Hyd. Mill Cylinder

Model MH01 FC

A - Standard Rod

B - Differential Rod

Model Number	Bore	MM	CB	CD	CW	E	EE NPT	KK	L	M	A	P	Y	XC
MH01FC - 02A	2	1	1 1/4	3/4	5/8	3 1/4	1/2	3/4-16	1 3/8	3/4	1	3 5/8	2 1/2	8 1/8
MH01FC - 02B		1 3/8						1-14			1 3/8		2 7/8	8 1/2
MH01FC - 03A	3	1 3/8	1 1/2	1	3/4	4 3/4	3/4	1-14	1 5/8	1 1/8	1 3/8	4 1/4	3 1/8	9 3/4
MH01FC - 03B		2						1 1/2-12			2		3 1/2	10 1/8
MH01FC - 04A	4	1 3/4	2	1 3/8	1	6 3/8	3/4	1 1/4-12	1 7/8	1 1/4	1 3/4	4 1/2	3 3/8	10 1/2
MH01FC - 04B		2 1/2						1 7/8-12			2 1/2		3 7/8	11
MH01FC - 05A	5	2	2 1/2	1 3/4	1 1/4	7 3/8	1	1 1/2-12	2 1/8	1 3/8	2	5 3/8	3 11/16	12 1/8
MH01FC - 05B		3 1/2						2 1/2-12			3 1/2		4 13/16	13 1/4
MH01FC - 06A	6	2 1/2	2 1/2	2	1 1/4	8 7/8	1 1/4	1 7/8-12	2 5/8	1 5/8	2 1/2	6 1/8	3 7/8	13 3/4
MH01FC - 06B		4 1/4						3-12			4 1/4		5 3/8	15 1/4
MH01FC - 08A	8	3	3	2	1 1/2	11 1/4	1 1/4	2 1/4-12	3 3/16	1 7/8	3	7	4 1/2	15 13/16
MH01FC - 08B		5 3/4						4-12			5 3/4		6 5/8	17 15/16
MH01FC - 10A	10	3 1/2	3 1/2	2 1/2	1 3/4	15	1 1/2	2 1/2-12	3 11/16	2 3/8	3 1/2	8 5/8	5	18 5/8
MH01FC - 10B		5 3/4						4-12			5 3/4		6 3/4	20 3/8
MH01FC - 12A	12	4 1/4	4 1/2	3	2 1/4	18	1 1/2	3-12	4 3/16	2 7/8	4 1/4	9 1/2	5 3/4	20 3/4
MH01FC - 12B		5 3/4						4-12			5 3/4		6 3/4	21 3/4
MH01FC - 14A	14	5 3/4	5	3 1/2	2 1/2	20	2	4-12	5	3 3/8	5 3/4	10 5/8	7	24 3/16
MH01FC - 14B		7						5-12			7		7 3/4	24 15/16
MH01FC - 16A	16	5 3/4	6	4 1/4	3	22	2	4-12	5 1/2	4	5 3/4	11 5/8	7	25 11/16
MH01FC - 16B		7						5-12			7		7 3/4	26 7/16

3000 PSI Hyd. Mill Cylinder

Model MH31 FC

A - Standard Rod

B - Differential Rod

Model Number	Bore	MM	CB	CD	CW	E	EE NPT	KK	L	M	A	P	Y	XC
MH31FC - 03A	3	1 3/4	2	1 3/8	1	5	3/4	1 1/4-12	2 7/16	1 1/4	1 3/4	6	5 3/4	15
MH31FC - 03B		2						1 1/2-12			2			
MH31FC - 04A	4	2	2 1/2	1 3/4	1 1/4	7 1/8	3/4	1 1/2-12	3	1 5/8	2	7	5 3/4	16 5/8
MH31FC - 04B		2 1/2						1 7/8-12			2 1/2			
MH31FC - 05A	5	2 1/2	2 1/2	2	1 1/4	8 1/2	1	1 7/8-12	3 7/16	2	2 1/2	7 15/16	6 11/32	18 3/4
MH31FC - 05B		3 1/2						2 1/2-12			3 1/2			
MH31FC - 06A	6	3	3	2	1 1/2	10	1 1/4	2 1/4-12	3 13/16	1 7/8	3	8 3/8	6 7/8	20 1/4
MH31FC - 06B		4 1/4						3-12			4 1/4			
MH31FC - 08A	8	4 1/4	4 1/2	3 1/2	2 1/4	13	1 1/4	3-12	5 1/2	4	4 1/4	9 1/4	7 3/4	23 3/4
MH31FC - 08B		5 3/4						4-12			5 3/4			
MH31FC - 10A	10	5	5 1/2	4	2 3/4	16 1/4	1 1/2	4-12	5 13/16	4 1/2	5	10 1/2	8 9/16	26 3/8
MH31FC - 10B		7						5-12			7			
MH31FC - 12A	12	5 3/4	6 1/2	5	3 1/4	19 1/2	1 1/2	4-12	6 3/4	5 1/2	5 3/4	11 3/8	8 5/16	28 1/8
MH31FC - 12B		8						5-12			8			
MH31FC - 14A	14	7	8	5 1/2	4	22	2	6-8	7 5/16	6	7	12 1/4	10	31 3/8
MH31FC - 14B		9						6-8			9			
MH31FC - 16A	16	8	9 1/2	6 1/2	4 3/4	25 1/2	2	7-8	8 1/4	7	8	13 5/8	10 11/16	34 5/8
MH31FC - 16B		10						7-8			10			

Cylinder Displacement & Flow

Cylinder Displacement

Pipe Flow Capacity

$$\frac{\text{DISPLACEMENT}}{\text{(Cu. In.)}} = \frac{\text{CYL. AREA}}{\text{(Sq. In.)}} \times \frac{\text{STROKE}}{\text{(Inches)}}$$

$$\text{AREA} = \frac{\text{GPM} \times 0.3208}{\text{VELOCITY (Ft./Sec.)}}$$

231 CUBIC INCHES = 1 GALLON

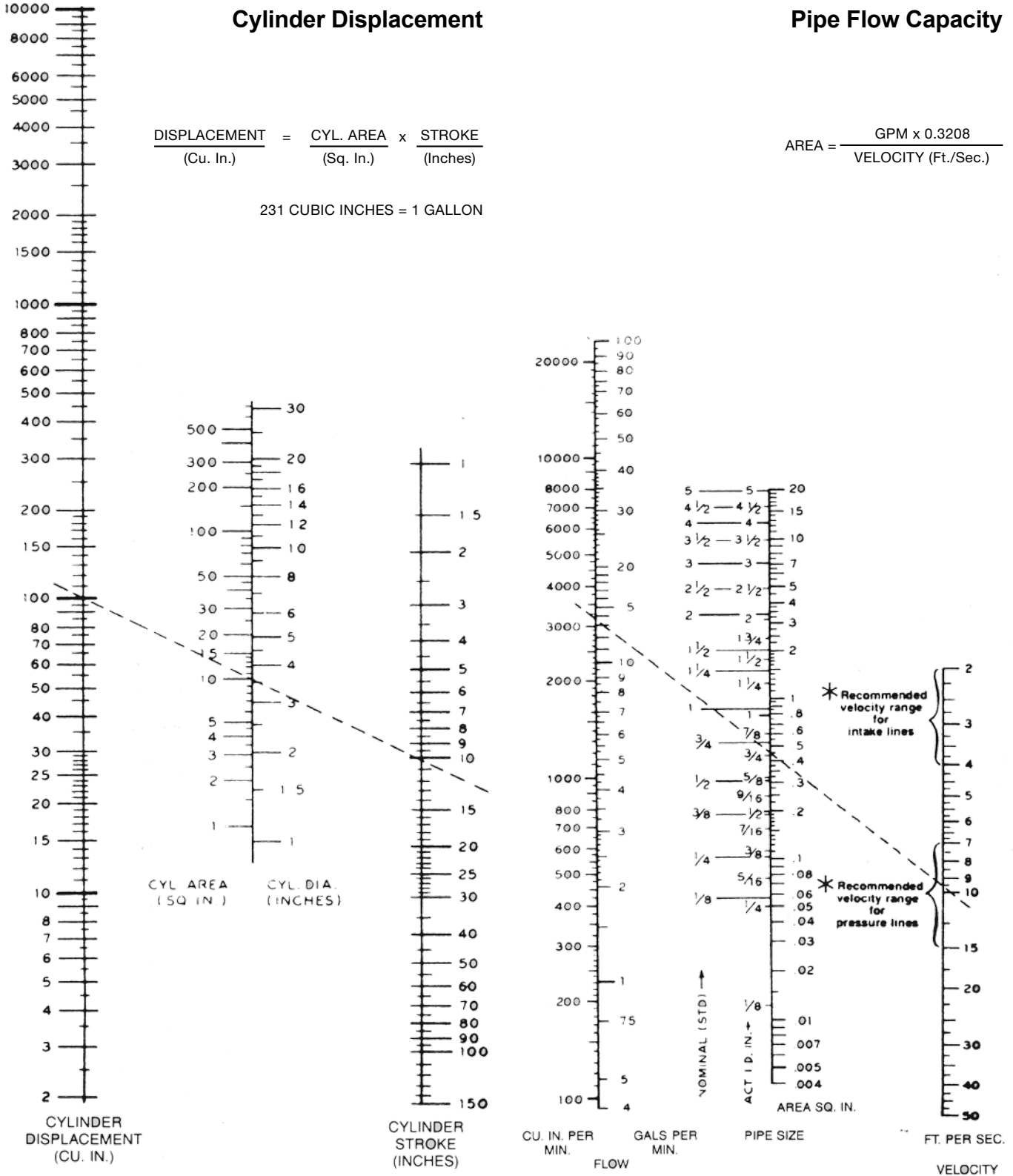

Cylinder Force & Speed

Cylinder Force

$$\frac{\text{FORCE}}{\text{(Pounds)}} = \frac{\text{CYL. AREA}}{\text{(Sq. In.)}} \times \frac{\text{LINE PRESSURE}}{\text{(Pounds per Sq. In.)}}$$

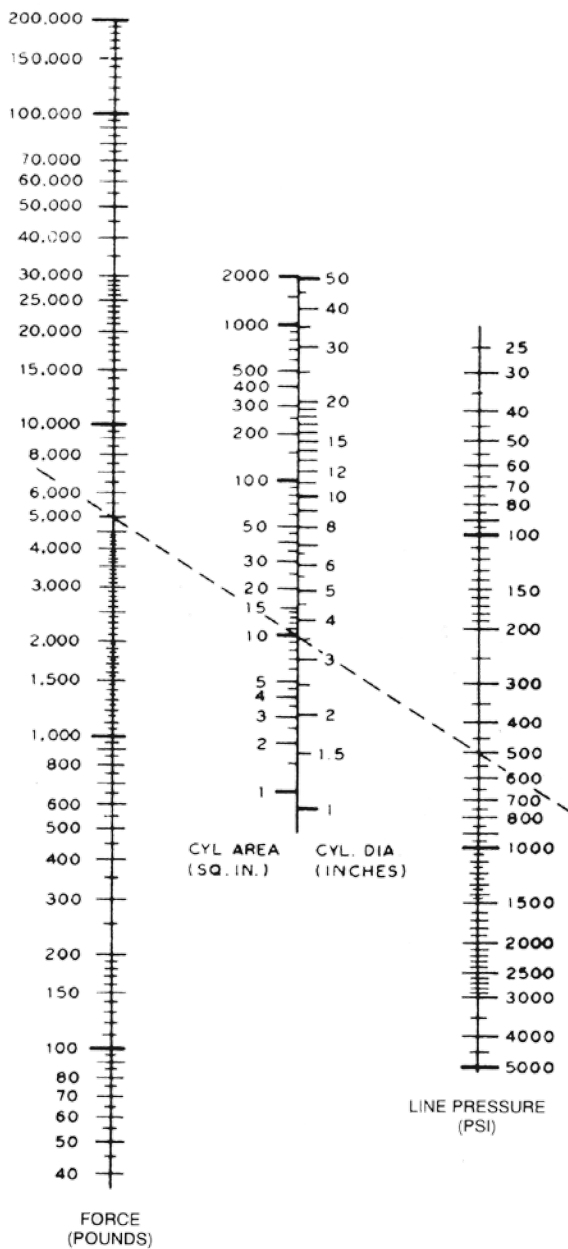

Cylinder Speed

$$\frac{\text{PUMP DELIVERY}}{\text{(Cu. In per Min.)}} \times \frac{\text{CYL. AREA}}{\text{(Sq. In.)}} \times \frac{\text{PISTOM VELOCITY}}{\text{(Inches per Minute)}}$$

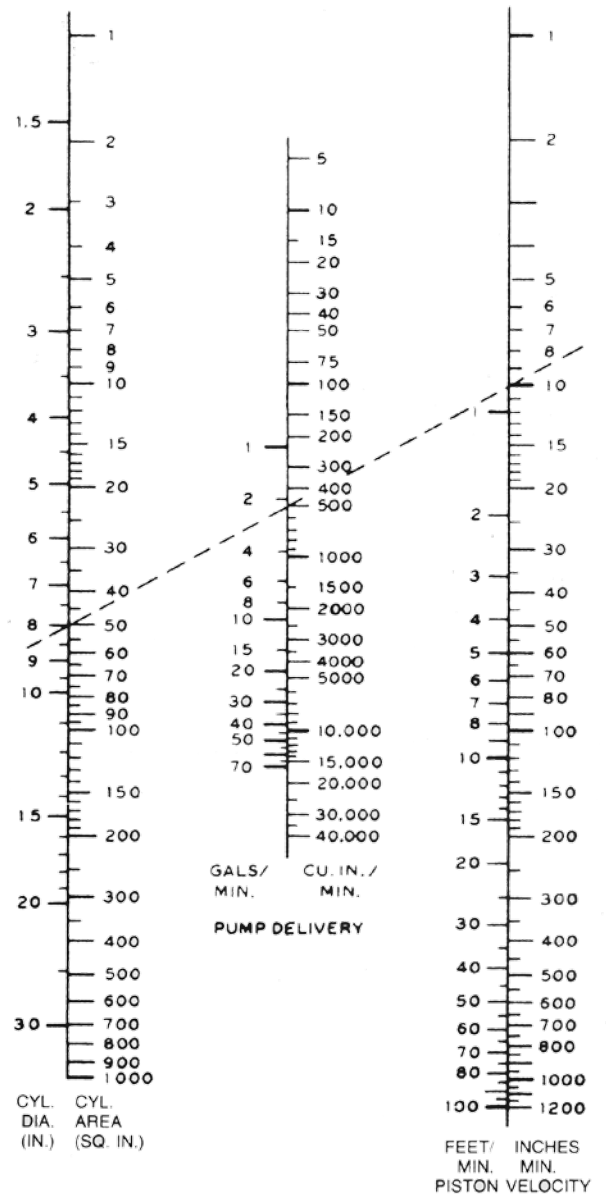

Accessories

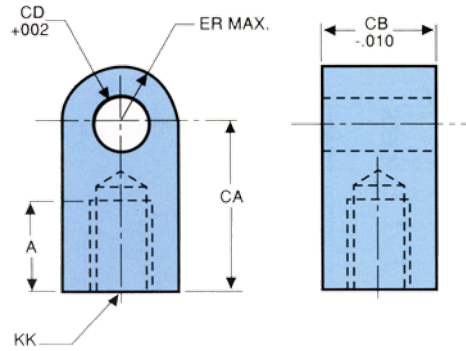

Female Rod Eye

Part Number	KK	CD	A	CA	CB	ER
7002.700.010	3/4-16	.752	1 1/8	2 1/16	1 1/4	3/4
7002.700.011	1-14	1.002	1 5/8	2 13/16	1 1/2	1
7002.700.012	1 1/4-12	1.377	2	3 7/16	2	1 3/8
7002.700.013	1 1/2-12	1.752	2 1/4	4	2 1/2	1 3/4
7002.700.014	1 7/8-12	2.002	3	5	2 1/2	2
7002.700.015	2 1/4-12	2.502	3 1/2	5 13/16	3	2 1/2

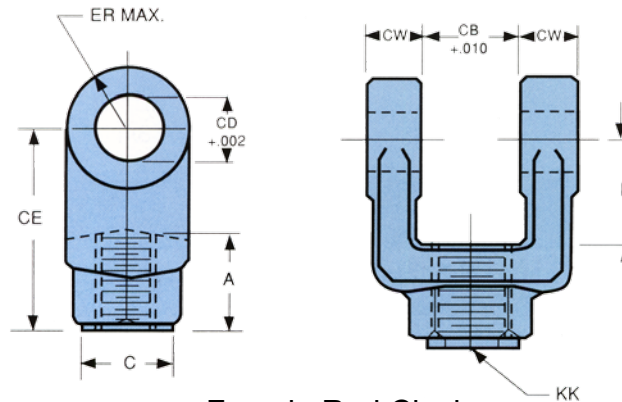

Female Rod Clevis

Part Number	KK	CD	C	CB	CE	CW	ER	F
7001.704.001	3/4-16	.752	1 1/4	1 1/4	2 3/8	5/8	3/4	1 1/4
7001.704.002	1-14	1.002	1 1/2	1 1/2	3 1/8	3/4	1	1 1/2
7001.704.003	1 1/4-12	1.377	2	2	4 1/8	1	1 3/8	2 1/8
7001.704.004	1 1/2-12	1.752	2 3/8	2 1/2	4 1/2	1 1/4	1 3/4	2 1/4
7001.704.005	1 7/8-12	2.002	3	2 1/2	5 1/2	1 1/4	2	2 1/2
7001.704.006	2 1/4-12	2.502	3 1/2	3	6 1/2	1 1/2	2 1/2	3

Accessories

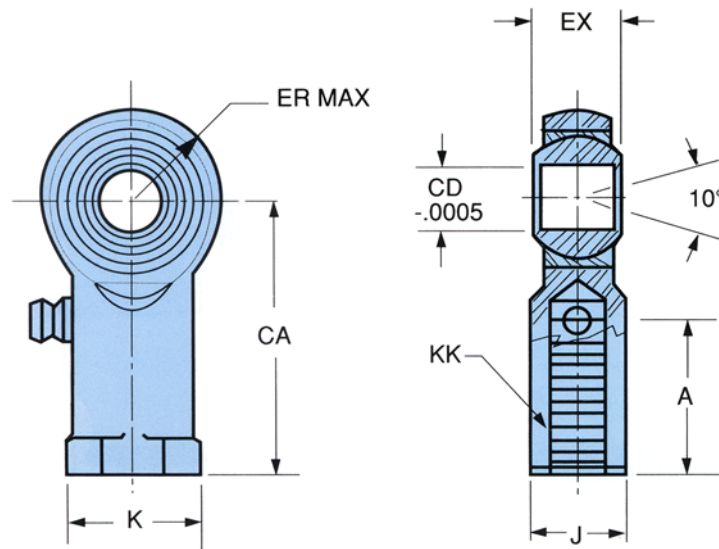

Female Rod Eye / Spherical Bearing

Part Number	KK	CD	A	CA	EX	ER	J	K	Static Load Lbs
7000.700.070	3/4-16	.750	1 9/16	2 7/8	7/8	7/8	1	1 1/8	13,831
7000.700.071	1-14	1.000	2 1/8	4 1/8	1 3/8	1 3/8	1 1/2	1 5/8	43,541
7000.700.072	1 1/4-12	1.250	2 1/8	4 1/8	1 3/32	1 3/8	1 1/2	1 5/8	44,500
7000.700.073	1 1/2-12	1.500	2 5/8	5 3/8	1 5/16	1 3/4	2	2 1/4	96,510
7000.700.074	2-12	2.000	4	8	1 3/4	2 1/2	2 3/4	3 1/8	225,450

Part Number	KK	JA	JD
7000.830.040	3/4-16	7/16	1 1/8
7000.830.041	1-14	9/16	1 1/2
7000.830.042	1 1/4-12	3/4	1 7/8
7000.830.043	1 1/2-12	7/8	2 1/4
7000.830.044	1 7/8-12	1 1/16	2 13/16
7000.830.045	2 1/4-12	1 1/4	3 3/8
7000.830.046	2 1/2-12	1 1/2	3 3/4
7000.830.047	3-12	1 3/4	4 1/2
7000.830.048	3 1/2-12	2	5 3/8
7000.830.049	4-12	2 1/4	6 1/8

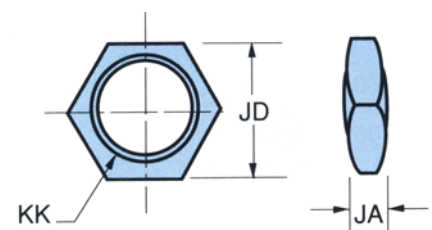

Rod End Jam Nut

Accessories

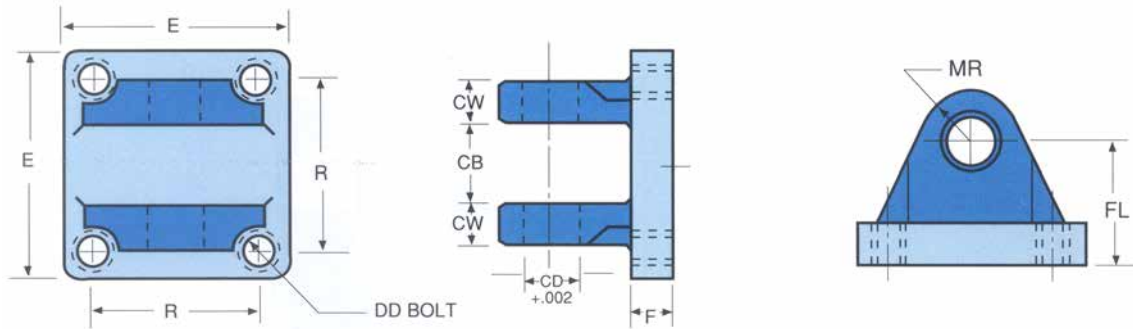

Clevis Bracket

Part Number	CD	CB	CW	DD Bolt	E	F	FL	MR	R
7002.708.010	.725	1 1/4	5/8	1/2-20	3 1/2	5/8	1 7/8	3/4	2 9/16
7002.708.011	1.002	1 1/2	3/4	5/8-18	4 1/2	3/4	2 1/4	1	3 1/4
7002.708.012	1.377	2	1	5/8-18	5	7/8	3	1 3/8	3 13/16
7002.708.013	1.752	2 1/2	1 1/4	7/8-14	6 1/2	7/8	3 1/8	1 3/4	4 15/16
7002.708.014	2.002	2 1/2	1 1/4	1-14	7 1/2	1	3 1/2	2	5 3/4
7002.708.015	2.502	3	1 1/2	1 1/8-12	8 1/2	1	4	2 1/2	6 19/32

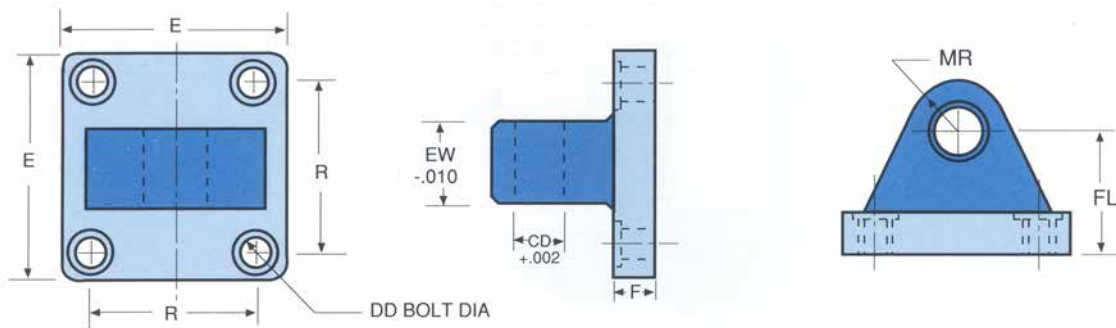

Eye Bracket

Part Number	CD	EW	DD Bolt	E	F	FL	MR	R
7001.708.020	.752	1 1/4	17/32	3 1/2	5/8	1 7/8	3/4	2 9/16
7001.708.021	1.002	1 1/2	21/32	4 1/2	3/4	2 1/4	1	3 1/4
7001.708.022	1.377	2	21/32	5	7/8	3	1 3/8	3 13/16
7001.708.023	1.752	2 1/2	29/32	6 1/2	7/8	3 1/8	1 3/4	4 15/16
7001.708.024	2.002	2 1/2	1 1/32	7 1/2	1	3 1/2	2	5 3/4
7001.708.025	2.502	3	1 5/32	8 1/2	1	4	2 1/2	6 19/32

Accessories

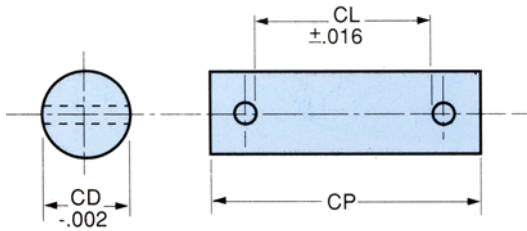

Cotter / Pivot Pin

Part Number	CD	CL	CP
7001.712.070	.750	2 9/16	3 1/8
7001.712.071	1.000	3 1/16	3 5/8
7001.712.072	1.375	4 1/16	4 3/4
7001.712.073	1.750	5 1/16	5 7/8
7001.712.074	2.000	5 1/16	5 7/8
7001.712.075	2.500	6 1/16	6 7/8

Part Number	CD	CL	CP
7003.712.001	.750	2 5/8	3 1/8
7003.712.002	1.000	3 1/8	3 5/8
7003.712.003	1.375	4 1/8	4 3/4
7003.712.004	1.750	5 1/8	5 7/8
7003.712.005	2.000	5 1/8	5 7/8
7003.712.006	2.500	6 1/8	6 7/8

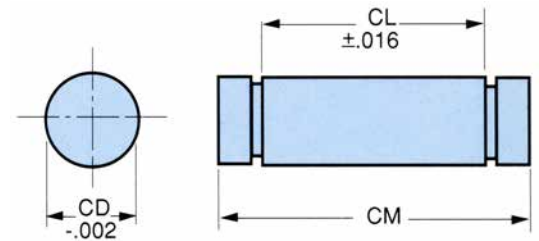

Snap Ring / Pivot Pin

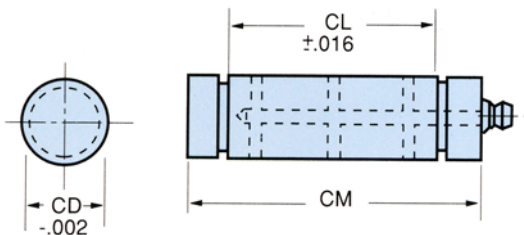

Greased Snap Ring / Pivot Pin

Part Number	CD	CL	CP
7002.712.010	.750	2 5/8	3 1/8
7002.712.011	1.000	3 1/8	3 5/8
7002.712.012	1.375	4 1/8	4 3/4
7002.712.013	1.750	5 1/8	5 7/8
7002.712.014	2.000	5 1/8	5 7/8
7002.712.015	2.500	6 1/8	6 7/8

Port Options

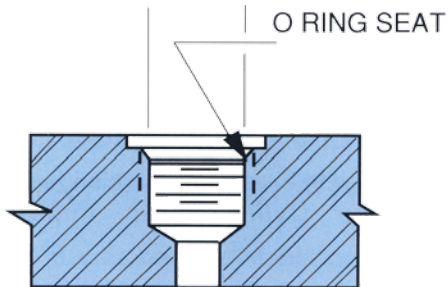

PORT TYPE J

Optional Female SAE "O" Ring

Thread Size	Dash Size	Thread I.D.	Threads Per Inch
9/16-18	-6	.50	18
3/4-16	-8	.69	16
1 1/16-12	-12	.97	12
1 5/16-12	-16	1.23	12
1 5/8-12	-20	1.55	12
1 7/8-12	-24	1.80	12
2 1/2-12	-32	2.42	12

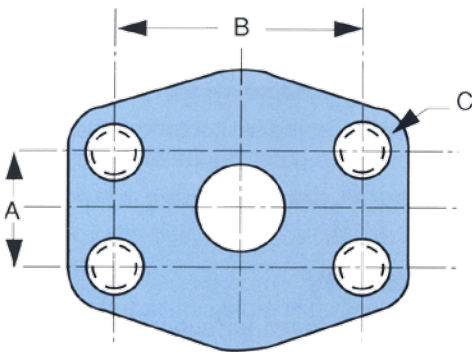

PORT TYPE F

Optional SAE Four Bolt Flanged Pad "Code 61"

Thread Size	Dash Size	A	B	C
3/4	-12	.88	1.88	3/8-16
1	-16	1.04	2.06	3/8-16
1 1/4	-20	1.18	2.32	7/16-14
1 1/2	-24	1.50	2.76	1/2-13
2	-32	1.68	3.06	1/2-13

Optional flanged ports will affect the cylinder envelope dimensions.

Code 62 flanges are available upon request.

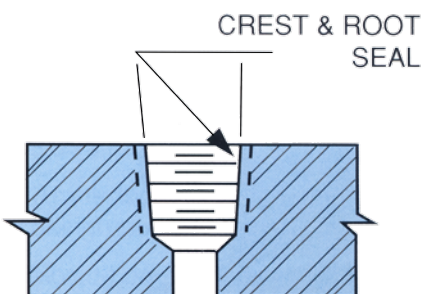

PORT TYPE P

Optional Female Pipe NPTF

Thread Size	Dash Size	Thread I.D.	Threads Per Inch
3/8	-6	.59	18
1/2	-8	.75	14
3/4	-12	.95	14
1	-16	1.20	11 1/2
1 1/4	-20	1.53	11 1/2
1 1/2	-24	1.78	11 1/2
2	-32	2.25	11 1/2
2 1/2	-40	2.75	11 1/2

Our Long History of Excellence is Your Guarantee of Success



Anker-Holth®

a division of Magnum Integrated Technologies Inc.

200 First Gulf Blvd, Brampton, ON, Canada, L6W4T5

Tel: 905-455-0402 Fax: 905-455-0422

www.ankerholth.com